

The ARTIST

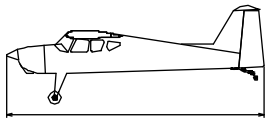

Order N°: 02037

Radio system you'll need :



1420 mm

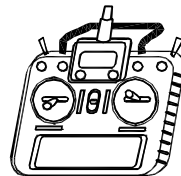

- ailerons - 2 servos
- elevator
- rudder
- motor

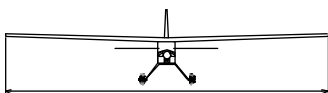

1560 mm



Dualsky 5050EA7

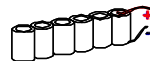

5S LiPo 2,7 - 4Ah

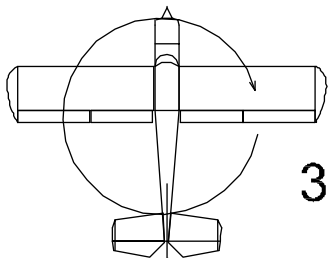

51,8dm²
36,7-44,4 g/dm²

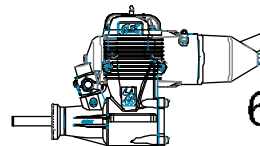

6,5ccm



1,9-2,3kg



NACA 64A014

Není-li uvedeno jinak, všechny neoznačené míry jsou v milimetrech
UNLES STATED, ALL DIMENSIONS ARE IN MILIMETERS

Manufactured by:

TOPMODEL CZ

679 05 HABRŮVKA 100 - CZECH REPUBLIC

www.topmodelcz.com

[e-mail:info@topmodelcz.cz](mailto:info@topmodelcz.cz)

UPOZORNĚNÍ!

- Tato stavebnice není hračka a není vhodná pro děti do 14 let.
- Nesprávné použití může způsobit poškození tohoto výrobku nebo zranění.
- Při použití tohoto modelu jste plně zodpovědní za své činy.
- Létejte v bezpečné vzdálenosti od obydlených zón. Před zapnutím rádia se ujistěte, že nikdo jiný nepoužívá stejnou frekvenci jako vy!
- Řiďte se pravidly pro létání v dané zemi.

POZNÁMKY K MONTÁŽI:

- Pokud lepíte díly ze sklolaminátu, tak povrch obruste (zdrsňte), týká se to také vnitřní strany laminátových trupů. Není-li uvedeno jinak, všechny neoznačené míry jsou v milimetrech
- Není-li uvedeno jinak, všechny neoznačené míry jsou v milimetrech
- Odstraňte potahovou folii v místě lepení potaženého dílu.
- Před montáží zkontrolujte otvory v pákách kormidel a pákách serv, popř. upravte jejich velikost.
- Před montáží serv do modelu zkontrolujte funkci serv pomocí servotestru.
- Trup s uříznutou přídí pro montáž elektromotoru má již správné vyosení, motorová přepážka se lepí dovnitř trupu, rovnoběžně s odřezanou částí.
- Křídla některých modelů větroňů mají na koncích úmyslné překroucení, tzv. „negativ“ - odtoková hrana na konci křídla směřuje nahoru.
- Úhly seřízení (úhel křídla, výškovky a vyosení motoru) zkontrolujte pomocí EWD váhy.
- Před prvním startem zkontrolujte, zda nejsou díly modelu zkroucené. Náprava je možná pomocí horkovzdušné pistole.
- Zkontrolujte polohu těžiště a v případě potřeby model dovažte vhodným závažím.
- Zkontrolujte smysl a velikost výchylek kormidel.

ATTENTION!

- This model construction kit is not a toy and is not suitable for children under the age of 14.
- Incorrect use of this model could cause material damage or personal injury.
- You are fully responsible for your actions when you use this model.
- Fly at a safe distance from occupied zones. Before switching on the radio, be sure, that no one else is using the same frequency as you !
- Follow the rules for flying in your country.

NOTES FOR ASSEMBLY:

- Unless stated, all dimensions are in millimeters
- If you are gluing fiberglass parts, sand (roughen) the surface, including the inside of the fiberglass fuselages.
- Always remove the covering foil at the point of gluing the covering part.
- Always insulate electrical cables and connectors with suitable insulation - eg. shrink tubing.
- Before mounting, check the holes in the control horns and servo arms, or adjust their size.
- Before mounting the servos inside the model, check the function of the servos with a servo tester.
- The fuselage with a cut nose for mounting the electric motor already has the correct misalignment. The motor mount must be glued inside the fuselage, parallel to the cut off part.
- Some glider wings have an intentional distortion, the so-called "negative" at the wingtips - the trailing edge at the wingtip points upwards.
- Check the adjustment angles with the incidence meter.
- Before first take-off check up please the center of gravity, the sense and size of the control surface angle and if model aeroplane parts aren't crooked. The reparation is possible through the use of hot-air dryer.

Part #	Part name	Material/dimensions	Loose	In bag	
	building instruction		01		
1	fuselage	balsa assembly	01		02037n-1ARF; 02037-1ARC
5	canopy frame	balsa assembly		01	
1-1	motor mount set				02037-MMS
1-1A	motor mount	fibreglass 3mm		01	
1-1B	motor mount	fibreglass 3mm		01	
1-1C	spacer	dural Ø6xØ8		01+03	
1-1D	screw	M3x8+M4x8		02+06	
1-1E	screw	M4x16		04	
1-1F	washer	steel Ø12x4		04	
1-1G	nut	M4		04	
1-2	servo tray	plywood 4x35x75mm		01	02037-1-2
1-3	battery tray	plywood 4x50x200mm		01	02037-1-3
2	wing	balsa assembly	02		02037n-2ARF; 02037-2ARC
2-1	aileron	balsa	02		
2-21	centering pin	fibreglass Ø5x30mm		02	FIBP-5x30
2-23	hook	steel Ø3mm		02	0205713400888
2-5	aileron pushrod	steel Ø1,7mm		02	1312141.1
2-6	clevis	clevis M2 steel, nut M2 steel		02+02	
2-8	aileron hom	fibreglass plate 1,5mm		02	05016
24	wing joiner	Alu tube Ø16x540mm		01	02037-24
3	horizontal stabilizer	balsa assembly	01		02037n-3ARF; 02037-3ARC
3-3	elevator joiner	steel Ø3mm		01	02037-3-3
3-5	elevator link	steel Ø1,7mm		01	1312141.1
3-6	clevis	clevis M2 steel, nut M2 steel		01+01	
3-8	elevator hom	fibreglass plate 1,5mm		01	05016
4	fin	balsa assembly	01		02037n-3ARF; 02037-3ARC
4-5	rudder link	steel Ø1,7mm		01	1312141.1
4-6	clevis	clevis M2 steel, nut M2 steel		01+01	
4-8	rudder hom	fibreglass plate 1,5mm		01	05016
5-1	centering pin	fibreglass Ø4x20mm		02	FIBP-4x20
5-2	canopy frame screw	plastic M3x12		02	2905
5-2	canopy frame nut	Al M3		02	1004 AL
551	cockpit interior	paper	01		02037-551
6	canopy	plastic	01		02037-6
7	stickers				02037n-7
8	wheel	Ø64		02	2MO219320
8-2	wheel axle	steel Ø4		02	2870 SZ
8-3	wheel colar	Al Ø9/4		02	2811 AL
9	engine cowl	fibreglass	01		02037n-9
9-1	engine cowl support	wood 7x15x15mm		05	02037n-9-1
9-2	engine cowl fixing	screw Ø2,9x9,5		05	0202995
9-5	throttle linkage	tube Ø3/2 x 340mm		01	M2C1000
		tube Ø2/1 x 430mm		01	M2V1000
		steel Ø0,8mm x 430mm		01	DO1508
9-6	clevis	nut M2 steel, clevis M2 steel		01+01	0102 SZ 1312141
9-7	threaded coupler	M2 brass		02	2012 BR
9-8	ball link	M2 brass/plastic		01	2408
10	landing gear	Al 3mm	01		02037-10
10-2	landing gear fixing	screw M3x16, washer, nut		03+06+03	020SC316 0703 SZ 0132 SZ
10-5	tailwheel	steel/plastic, wheel Ø23mm		01	02022-103
10-6	tailwheel fixing	screw Ø2,2x9,5mm		02	0512 SZ
11	pinned hinge	plastic 16x32mm		13	2502

RECOMMENDED EQUIPMENT				
		Pieces		Item No. www.topmodelcz.cz
transmitter	5 channel			
receiver	min 5 channel			
servo	SC-0254MG	2	for ailerons	1SV2304
	HS-5245MG DIGITAL	2	for rudder & elevator	1H13185
	HS-322 HD	1	for throttle	1H13065
motor	Duatsky 5050EA7	1		
controller	Xcontroller X065-LITE	1		1974
spinner	Ø51 + propeller adaptor	1		8KU10033 + 4706
propeller	13/8"	1		
battery	5S LIPo	1		

ATTENTION!

This model construction kit is not a toy and is not suitable for children under the age of 14.

Incorrect use of this model could cause material damage or personal injury.

You are fully responsible for your actions when you use this model.

Fly at a safe distance from occupied zones.

Before switching on the radio, be sure, that no one else is using the same frequency as you !

Before first take-off check up please the center of gravity, the sense and size of the control surface angle and if model aeroplane parts aren't crooked.

The reparation is possible through the use of hot-air dryer.

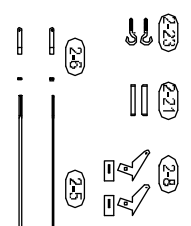
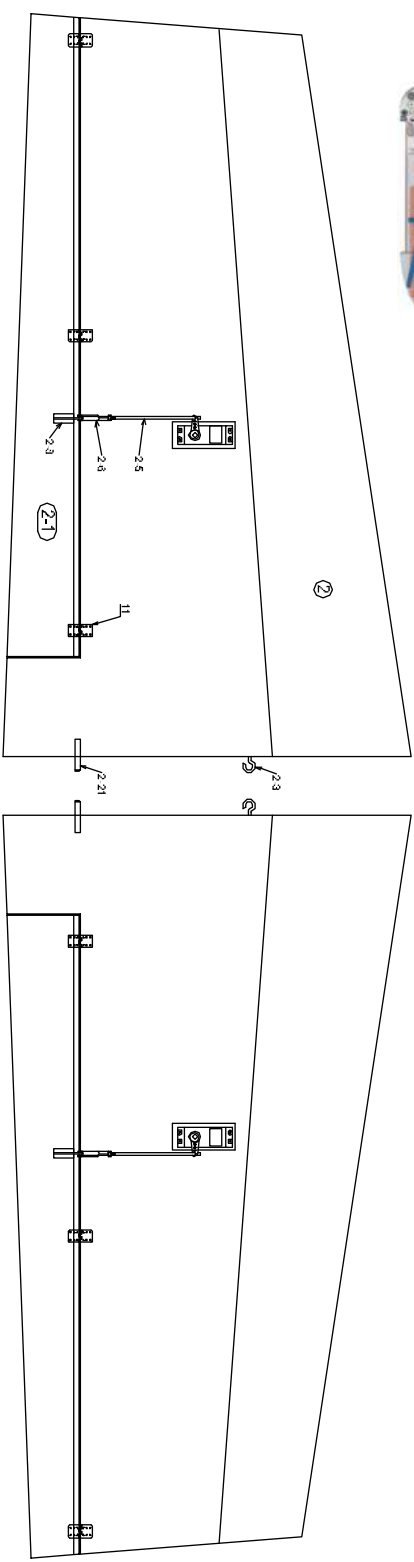
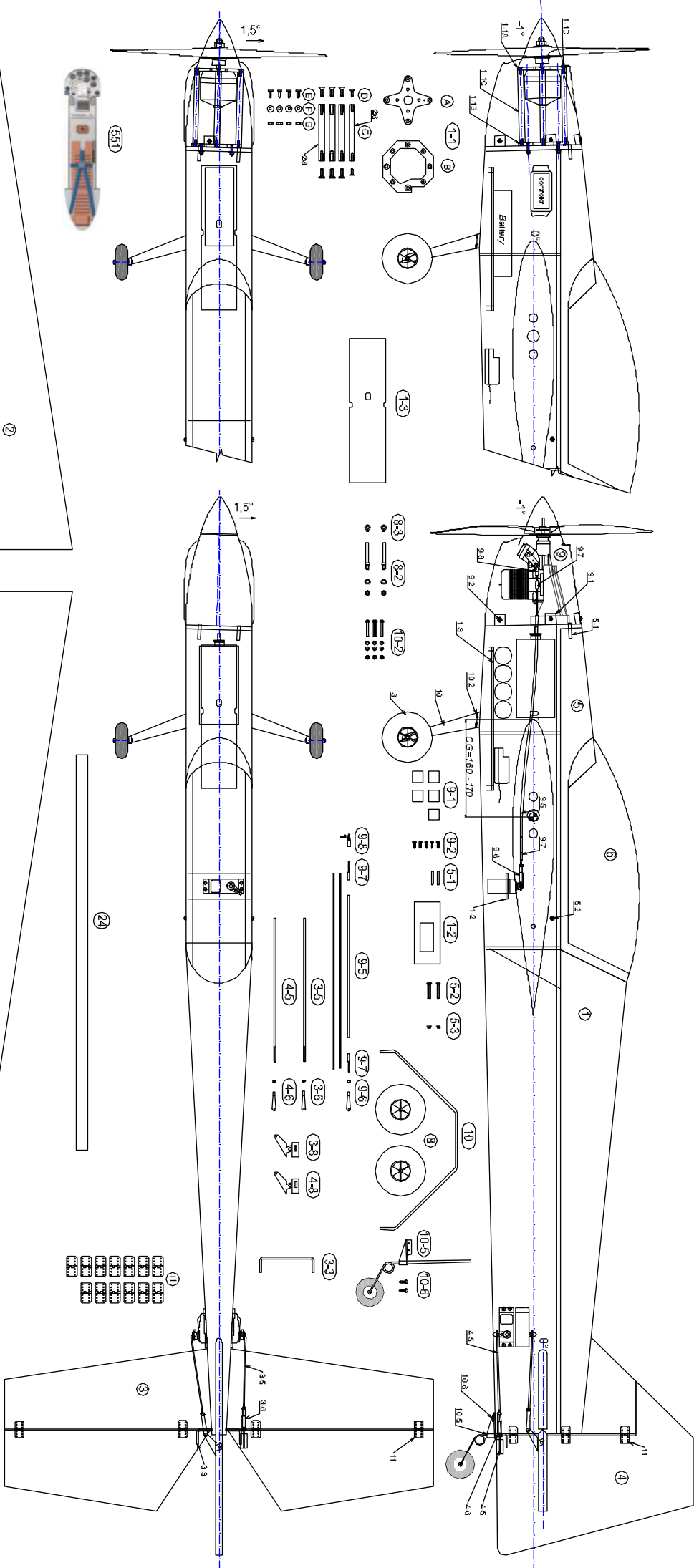

The ARTIST

© TOPMODEL CZ Manufactured by TOPMODEL CZ s.r.o. 679 05 HABRŮVKA 100, made in the Czech Republic
 www.topmodelcz.com e-mail: info@topmodelcz.cz

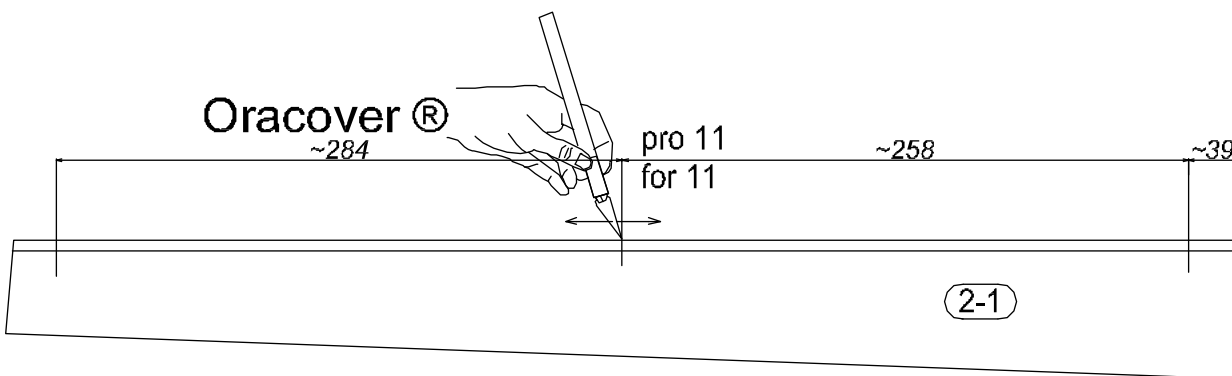
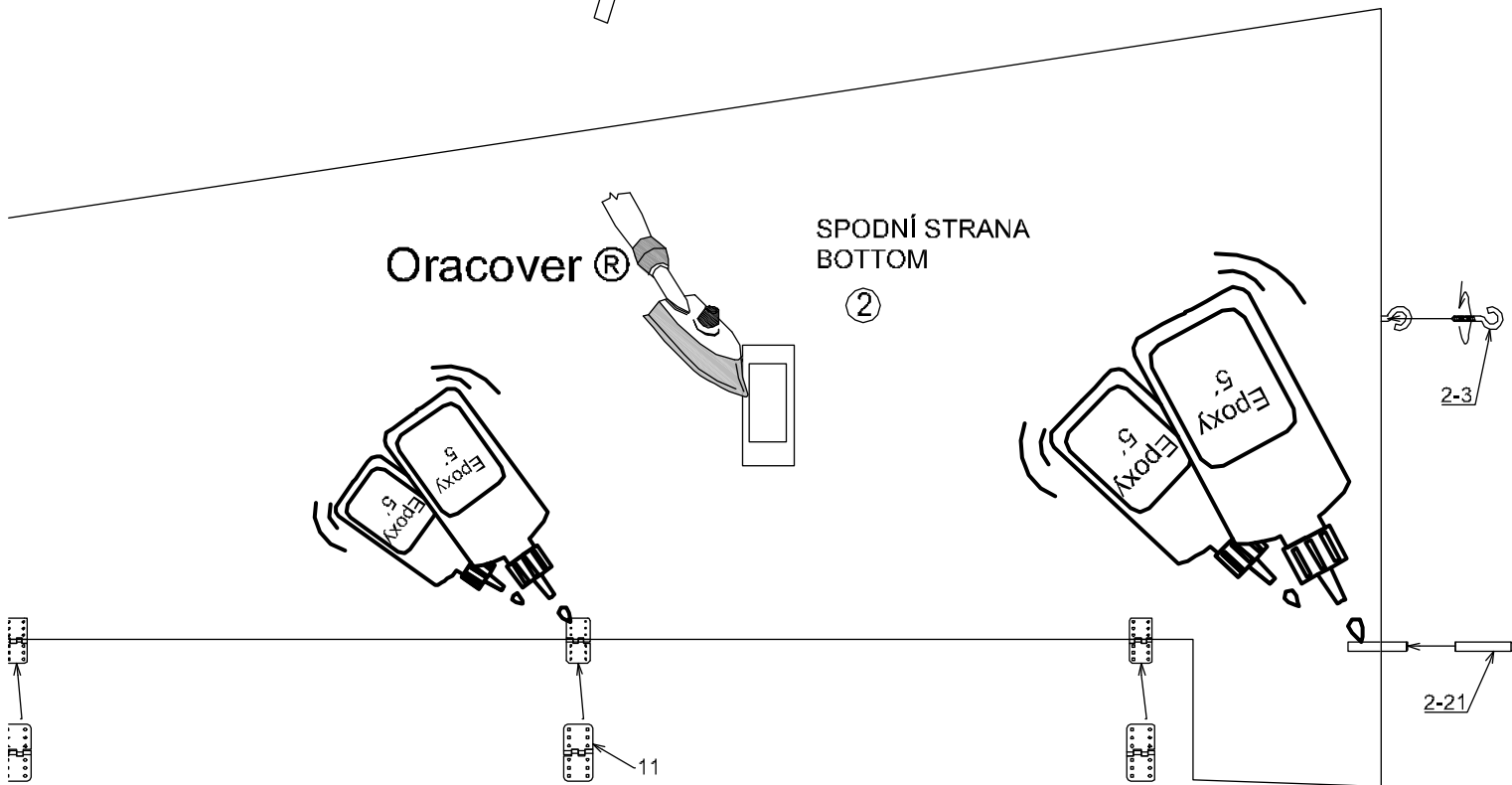
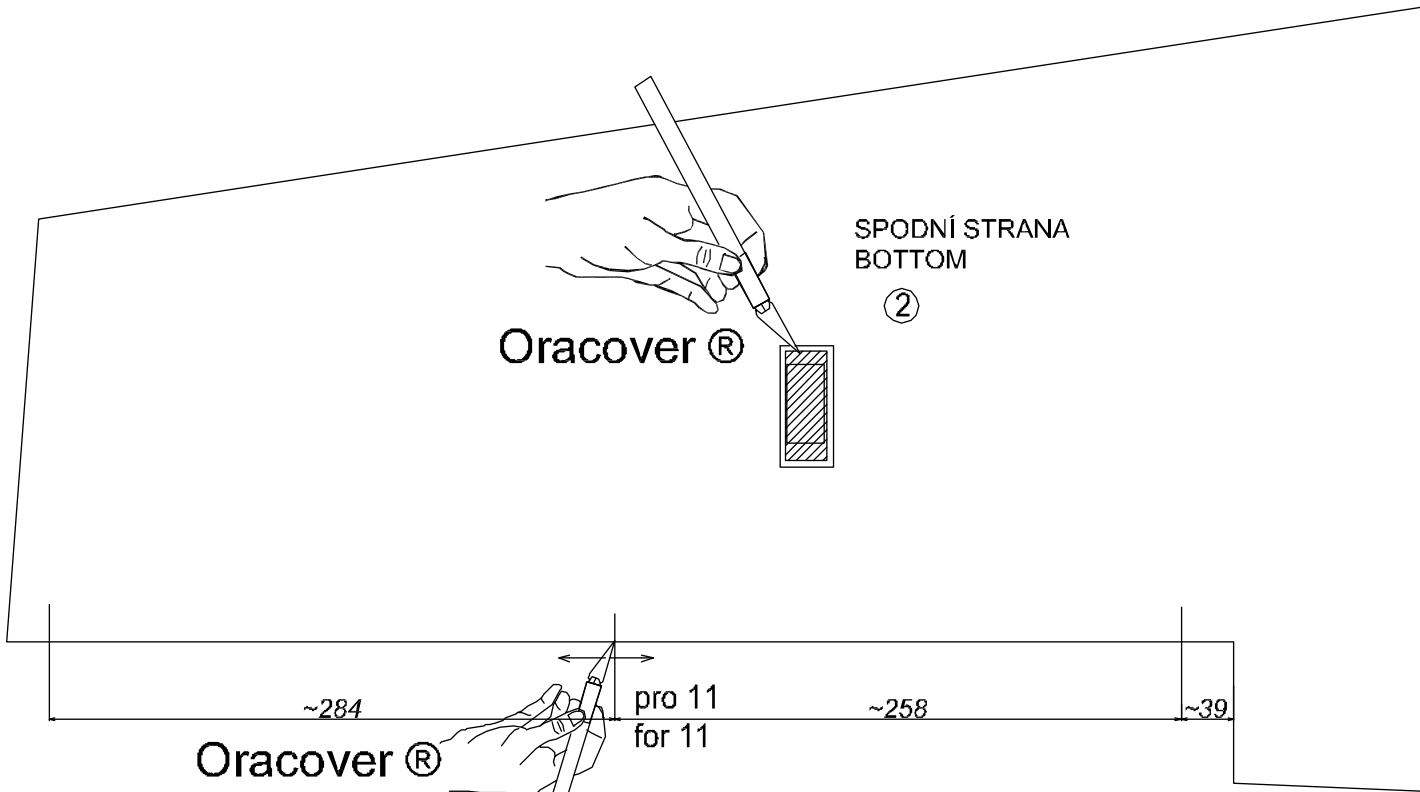

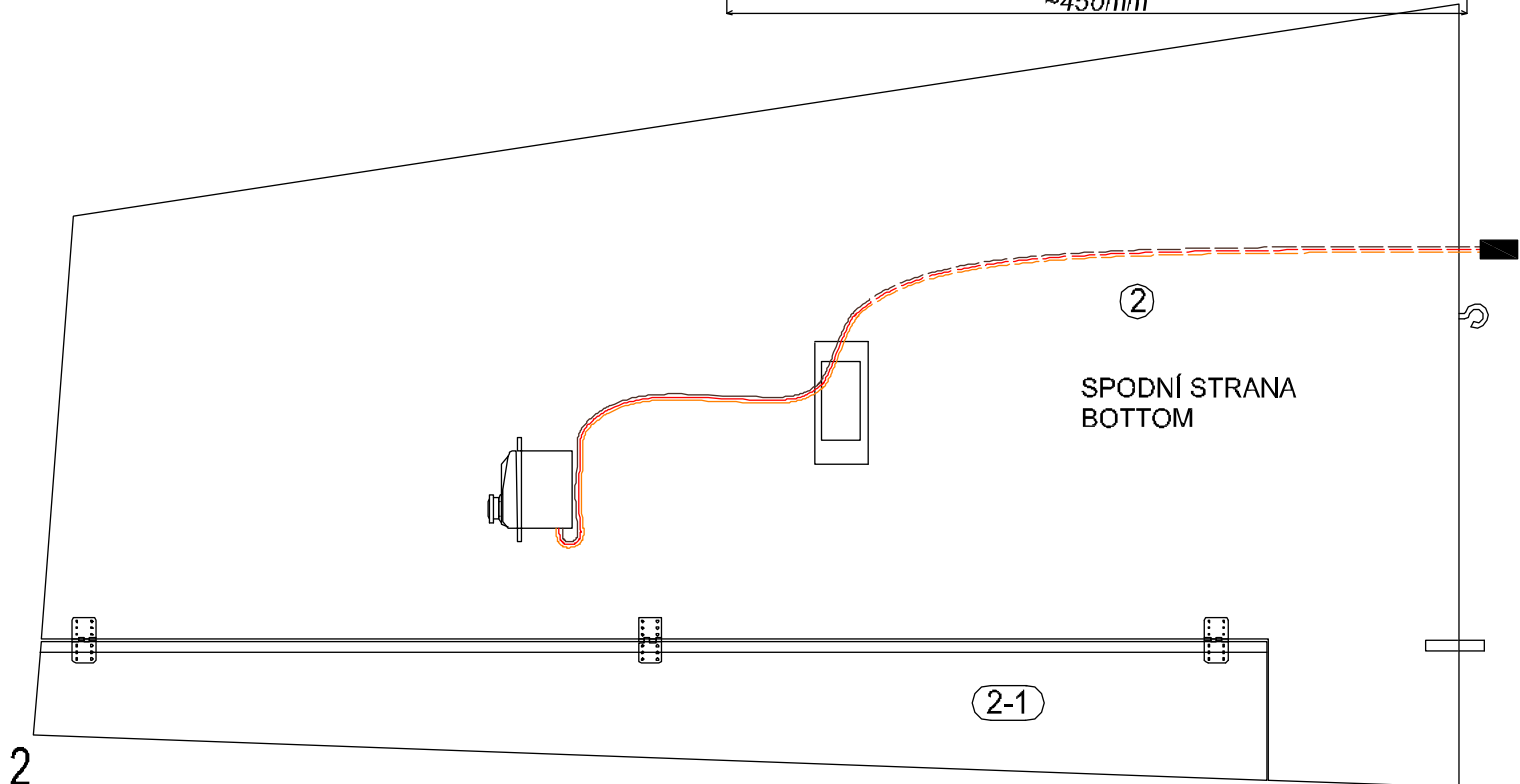
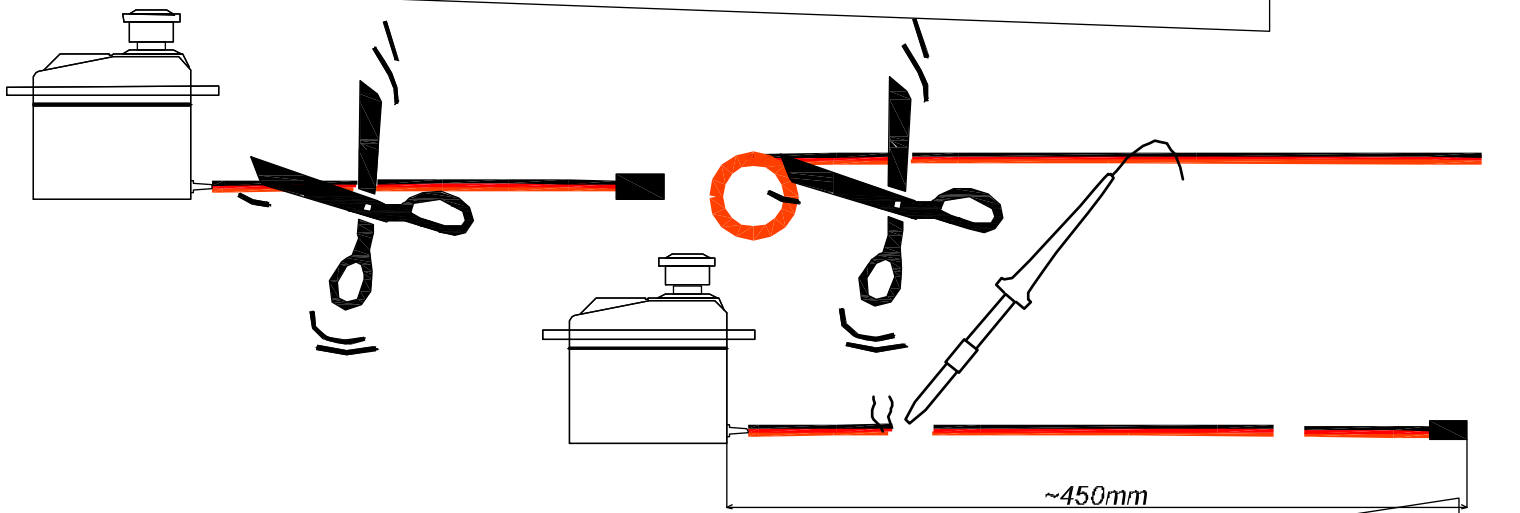
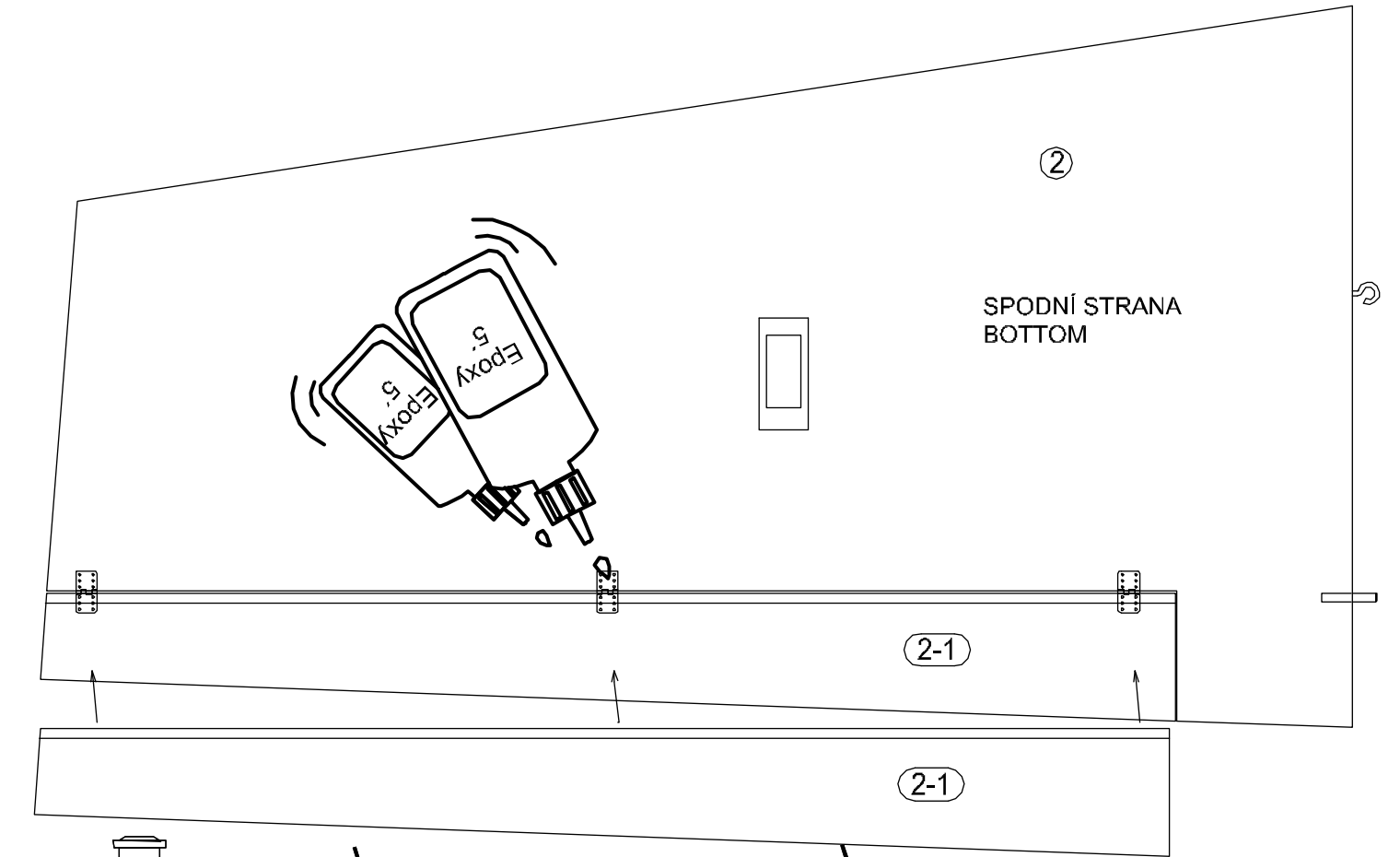

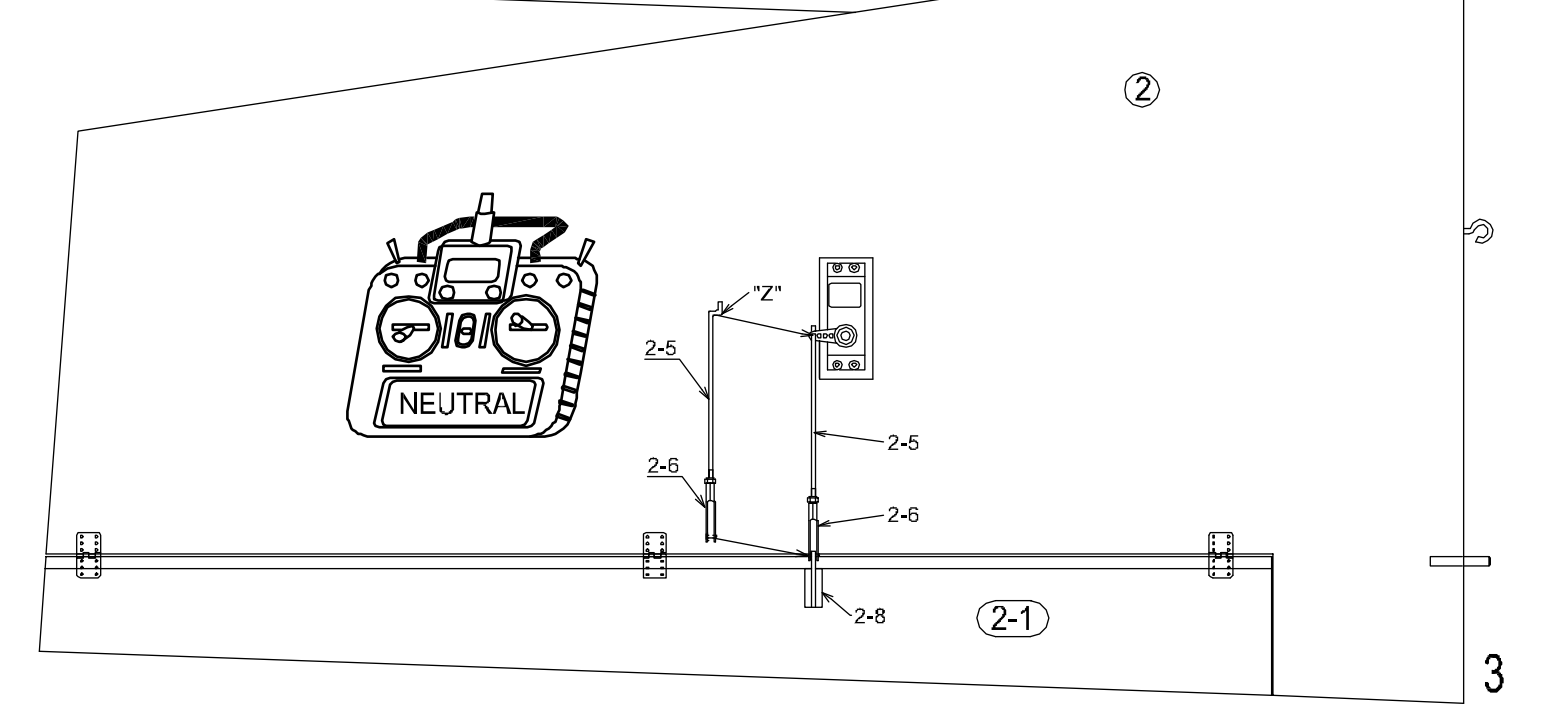
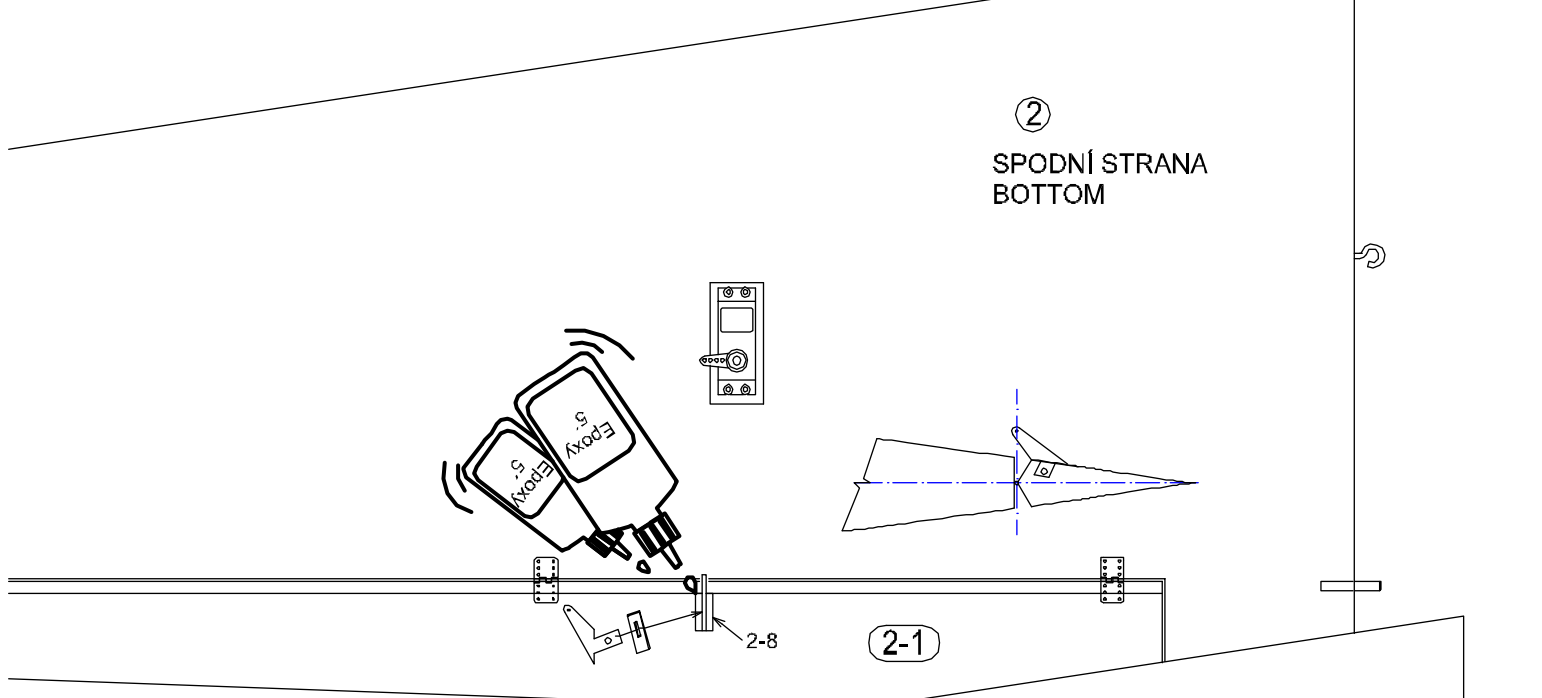
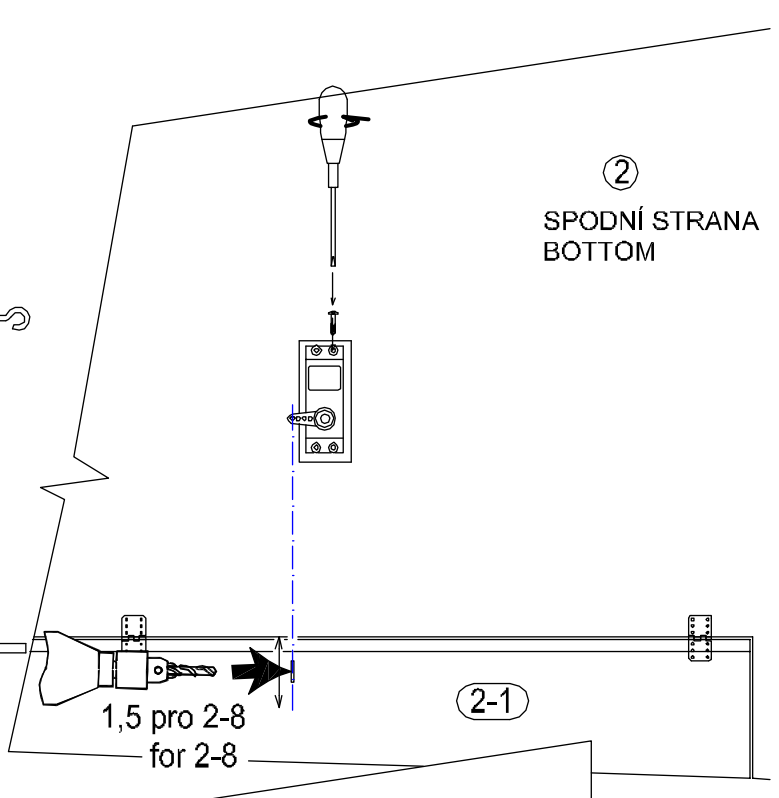
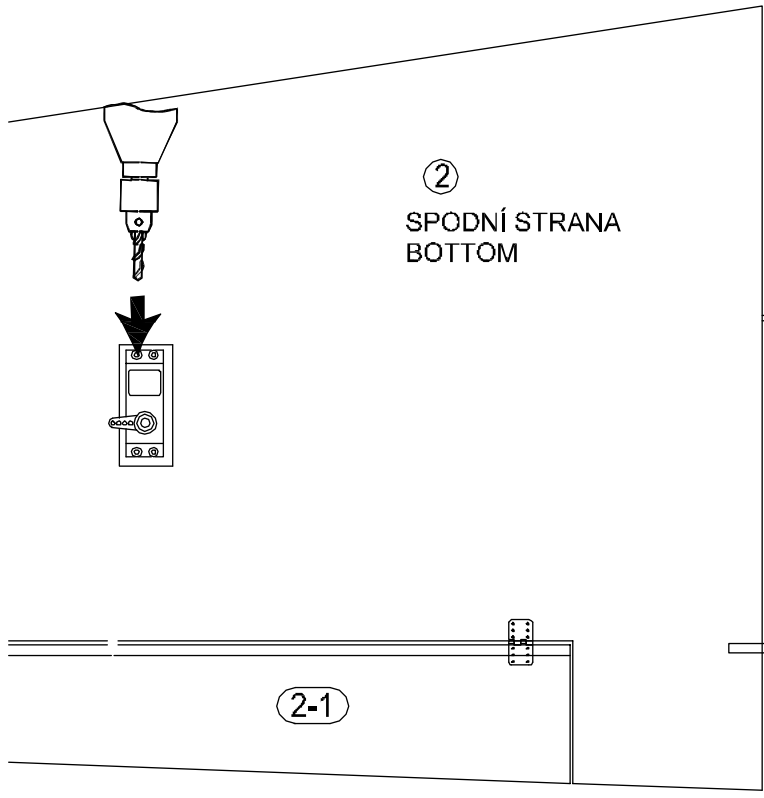

Oracover®

Left & Right side

Left & Right side

Right side

Left side

Top

6

~120

①

Oracover®

Ø3,1 pro 5-2
for 5-2

2x Ø4 pro 5-1
for 5-1

⑤

①

Ø3,1 pro 5-2
for 5-2

Ø5,2 pro 5-3
for 5-3

⑤

SPODNÍ STRANA
BOTTOM

5-3

4

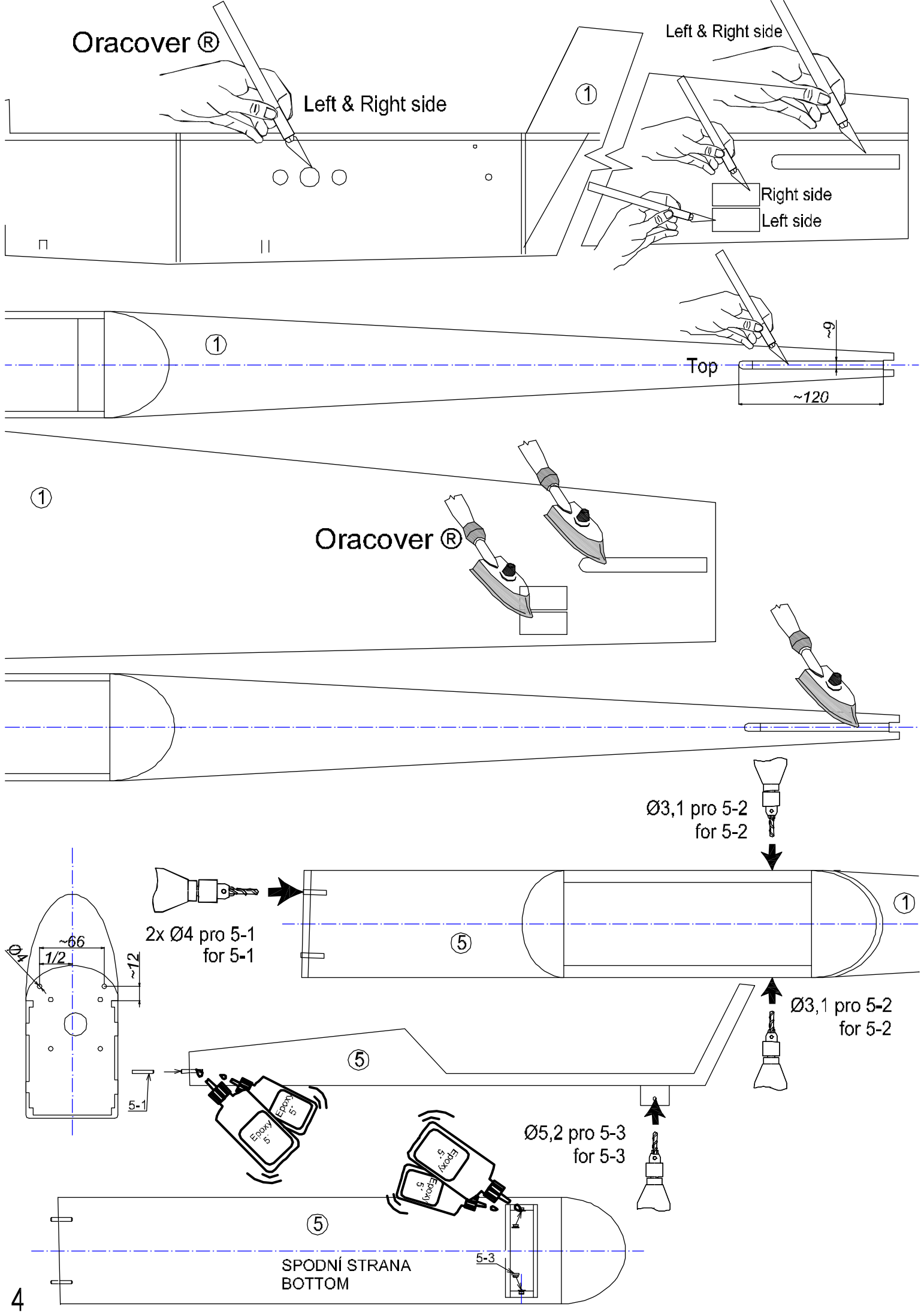

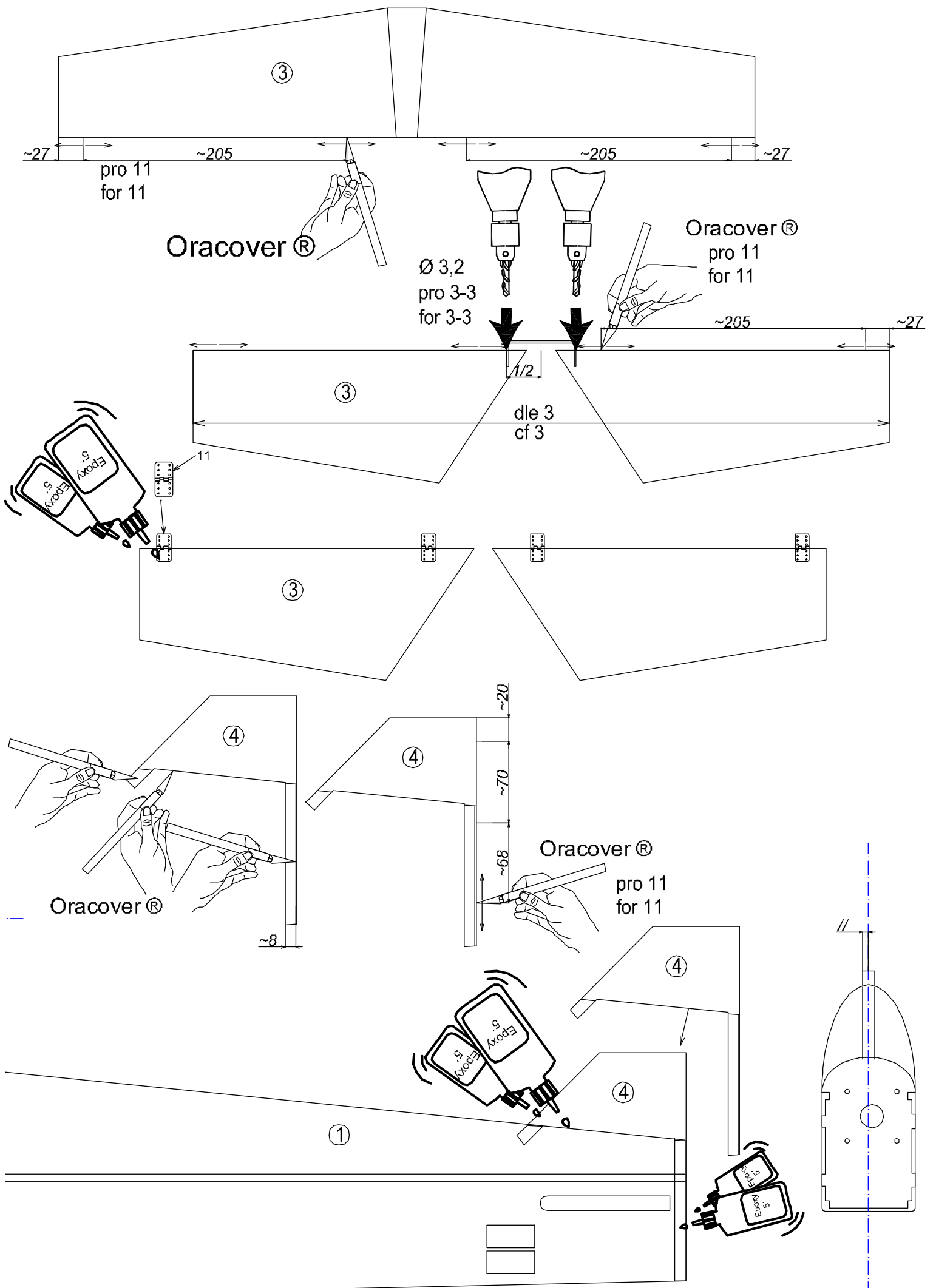

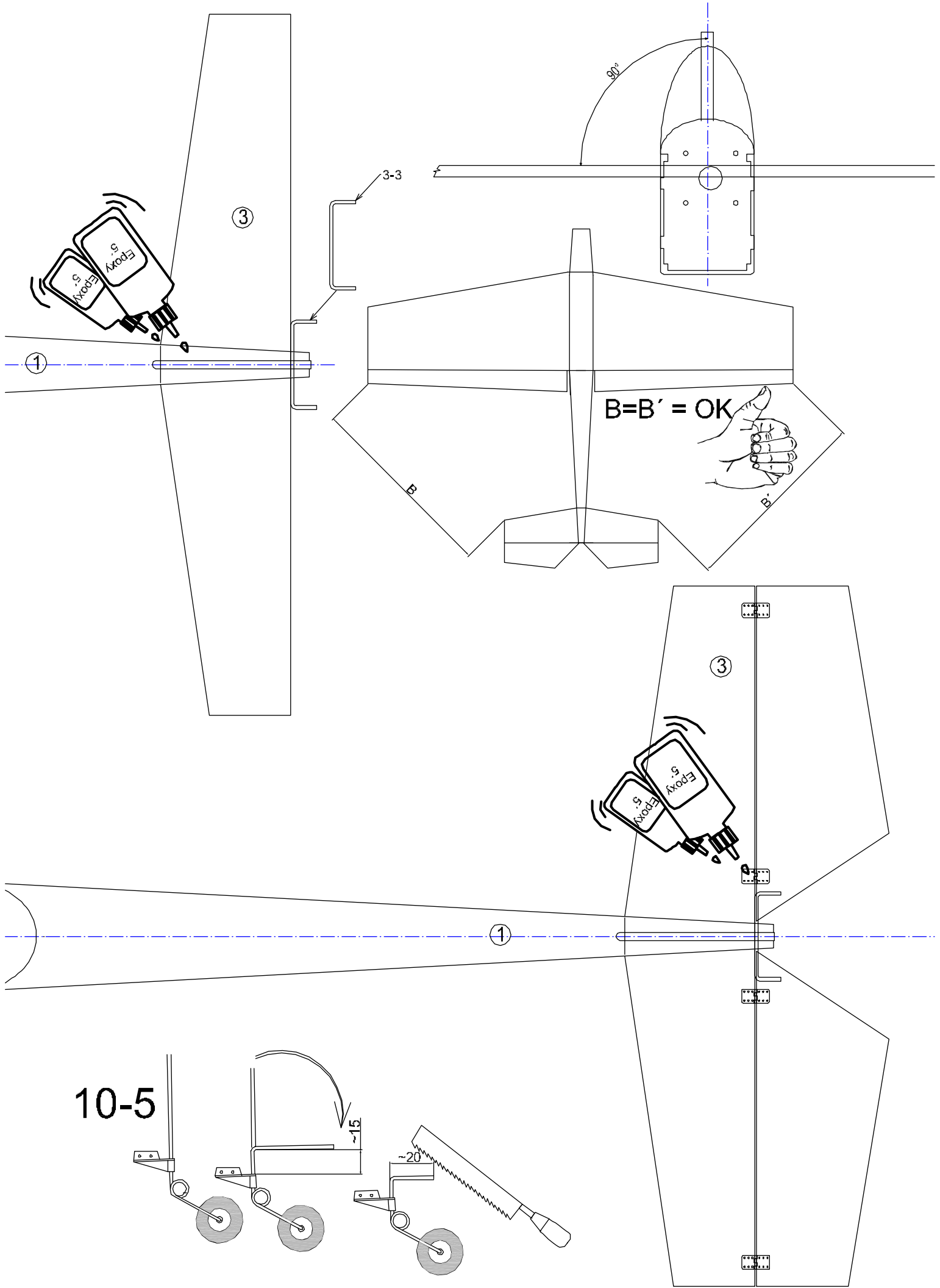

Ø 1,7 - 2x
pro 10-6
for 10-6

Oracover®
pro 10-5
for 10-5

BOTTOM
SPODNÍ STRANA

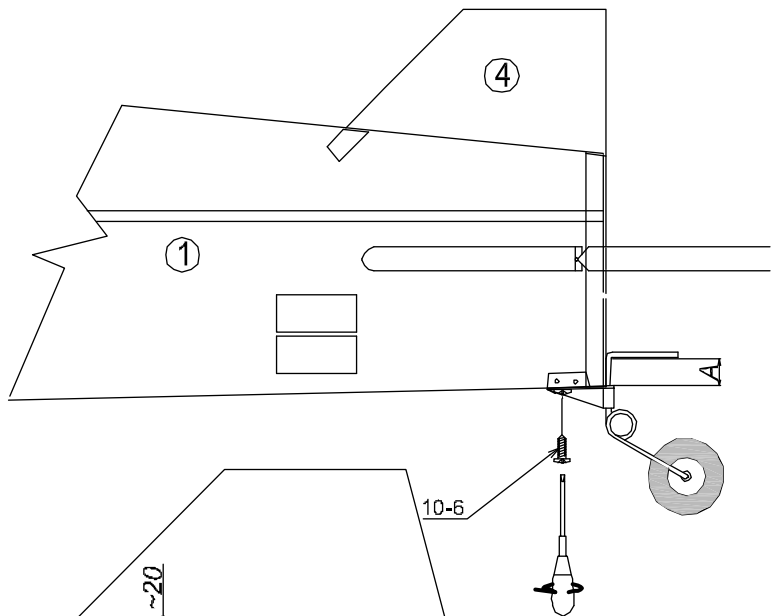
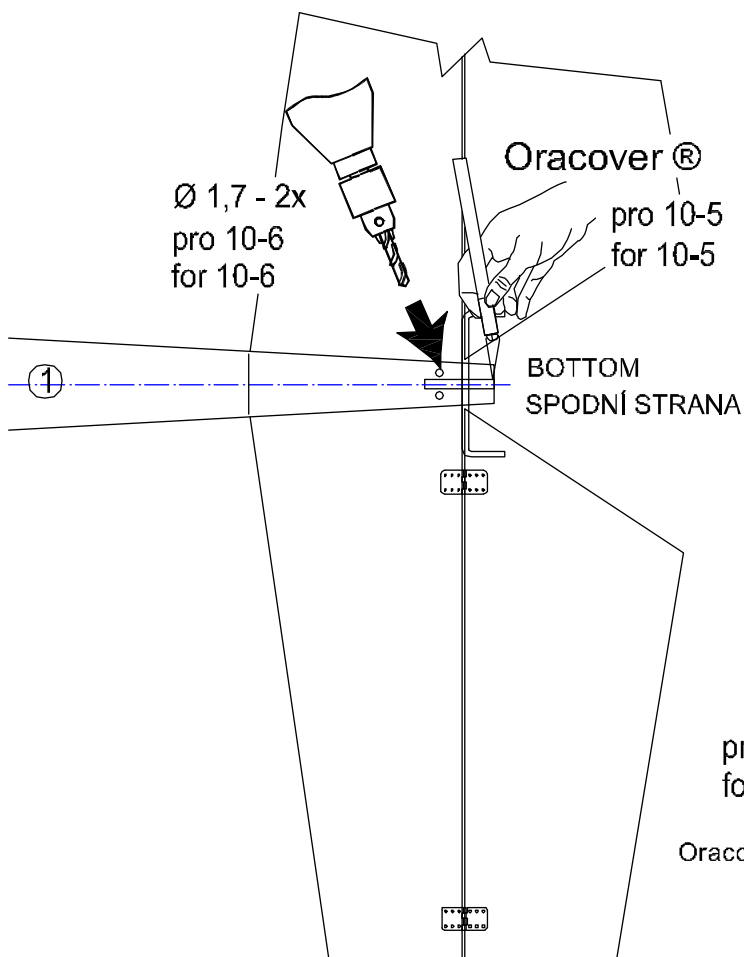

pro 11
for 11

Oracover®

Ø 2,2 pro 10-5
for 10-5

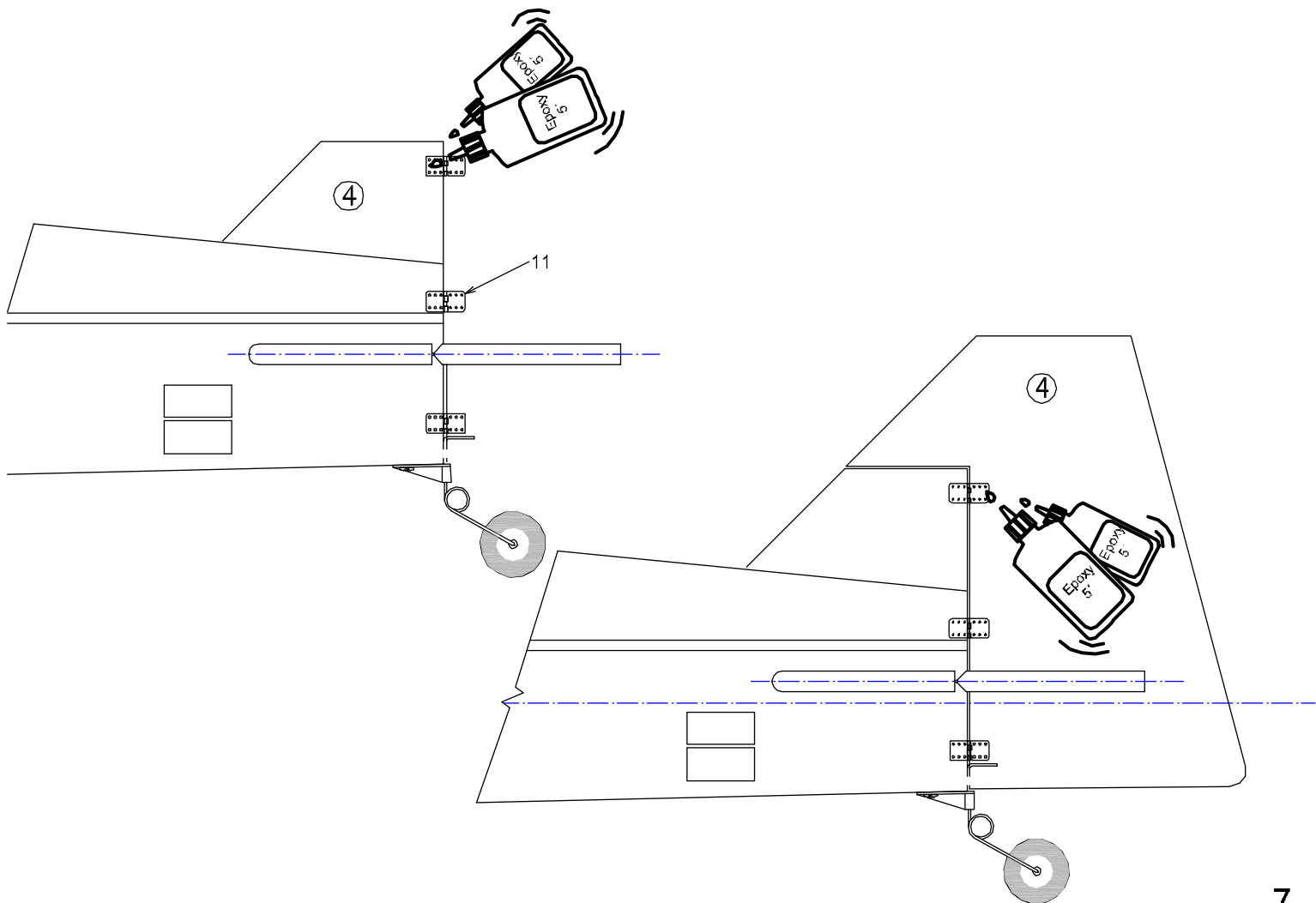
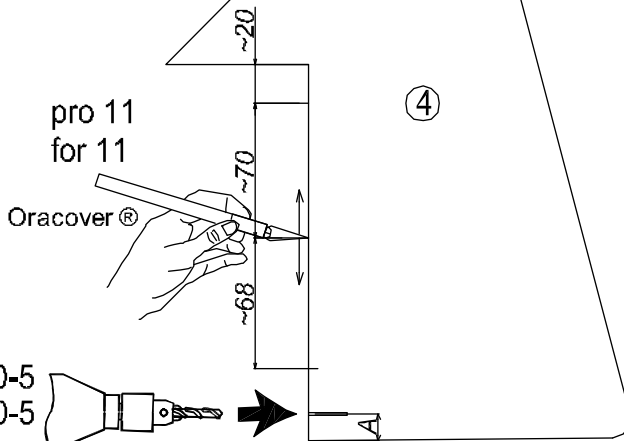

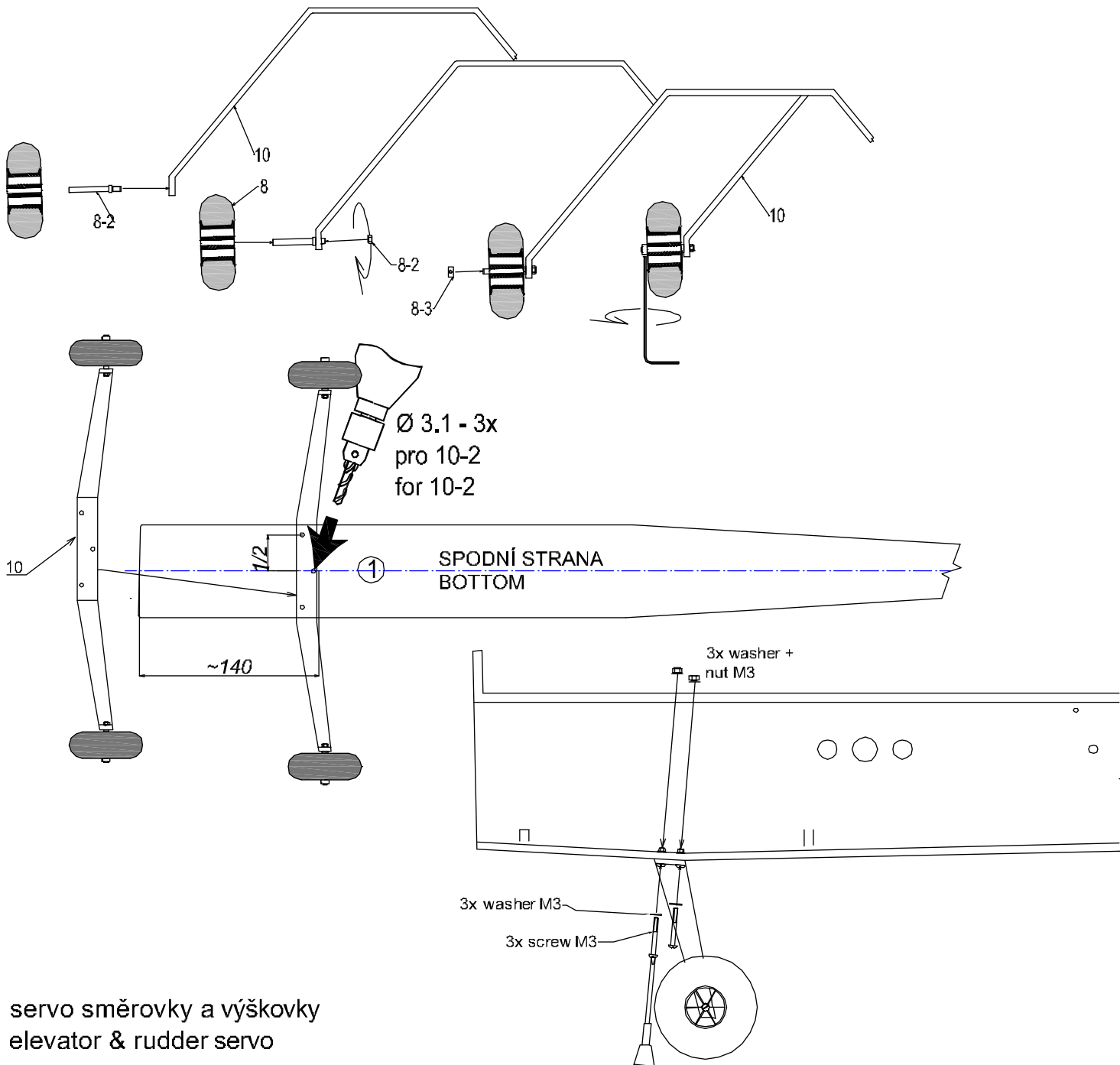

servo směrovky a výškovky
elevator & rudder servo

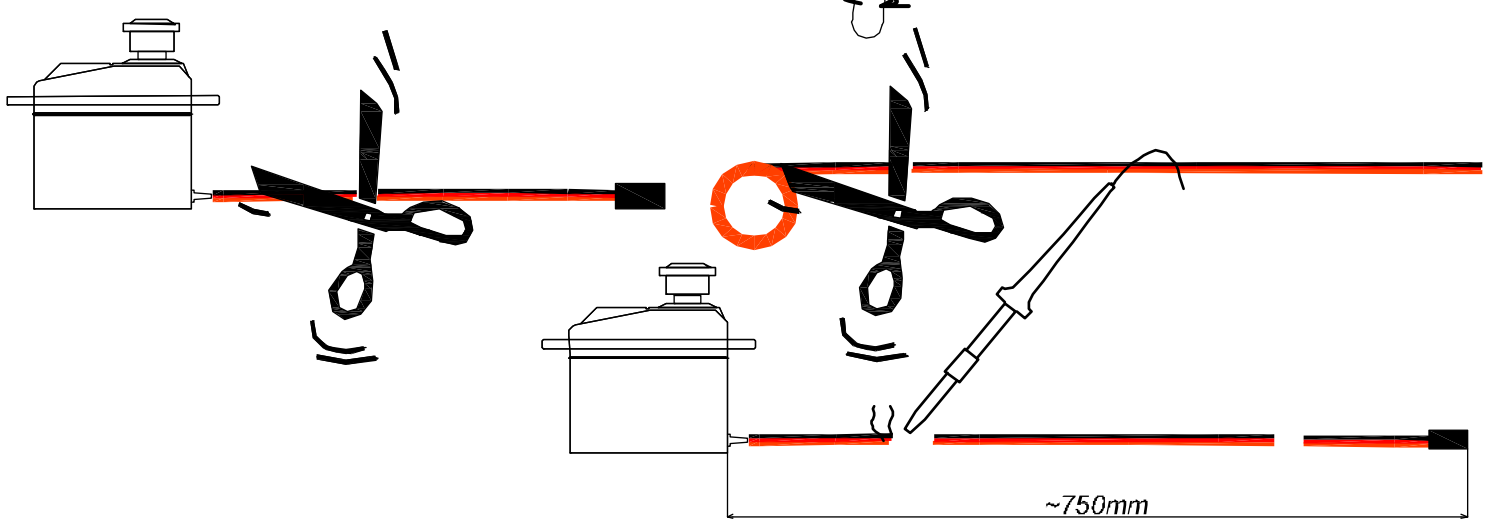

SPODNÍ STRANA
BOTTOM

SPODNÍ STRANA
BOTTOM

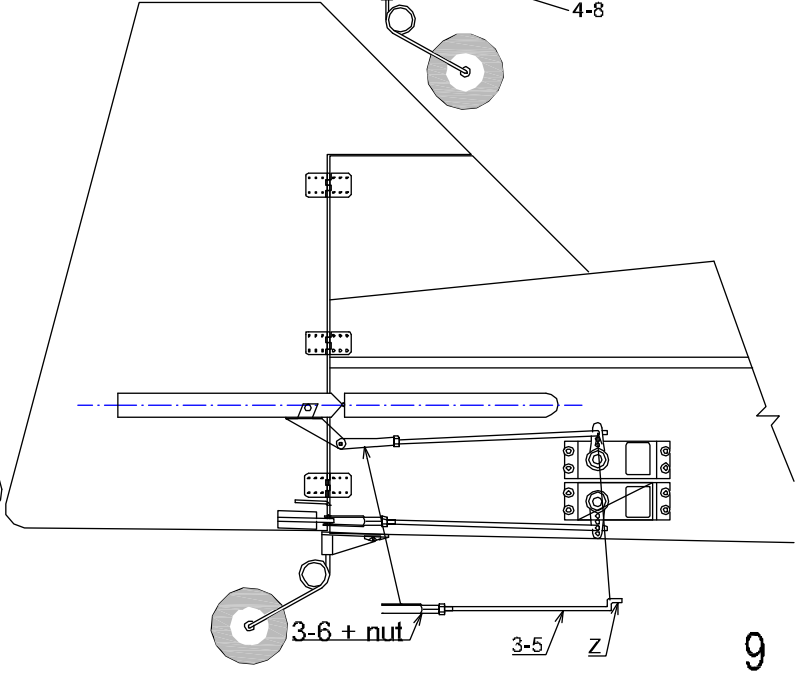
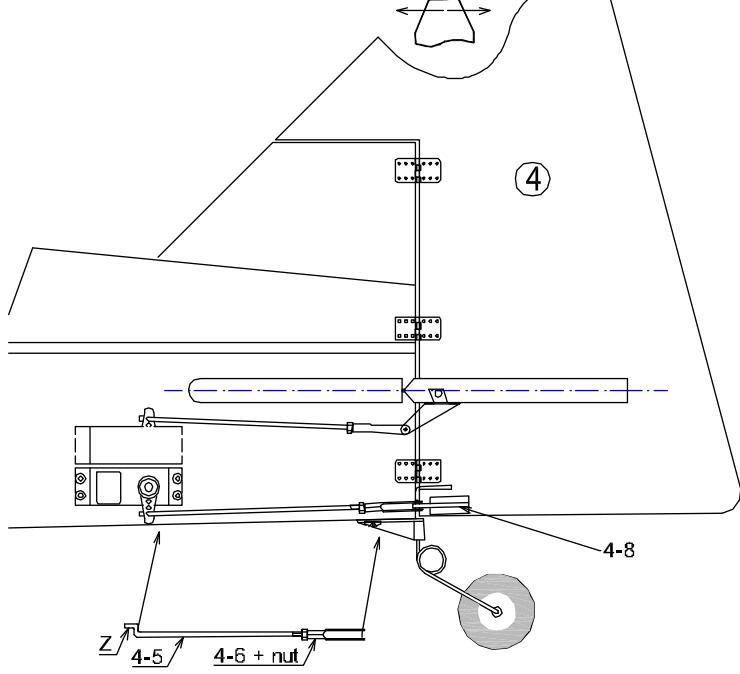
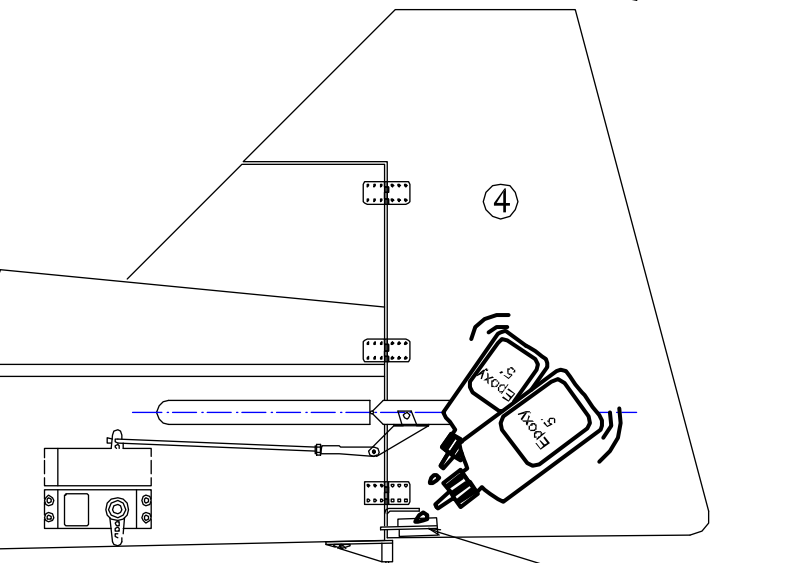
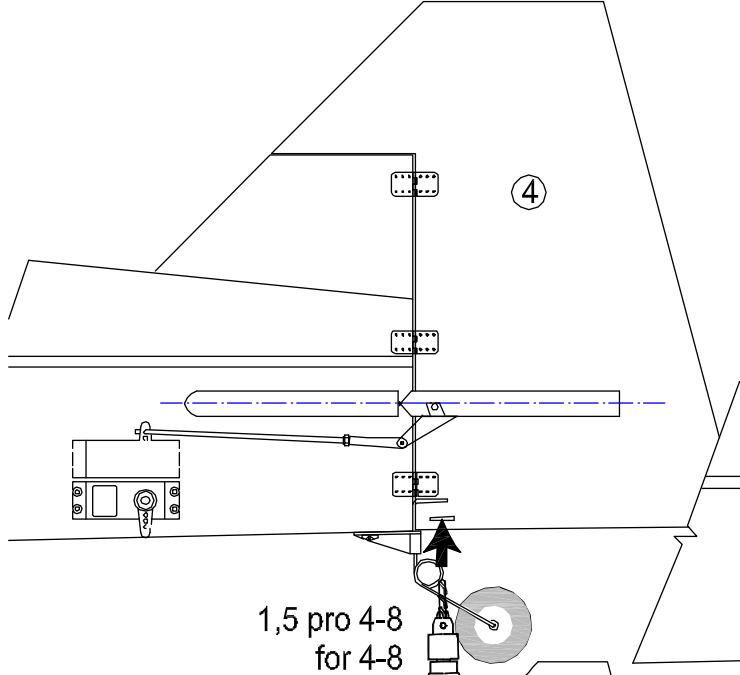
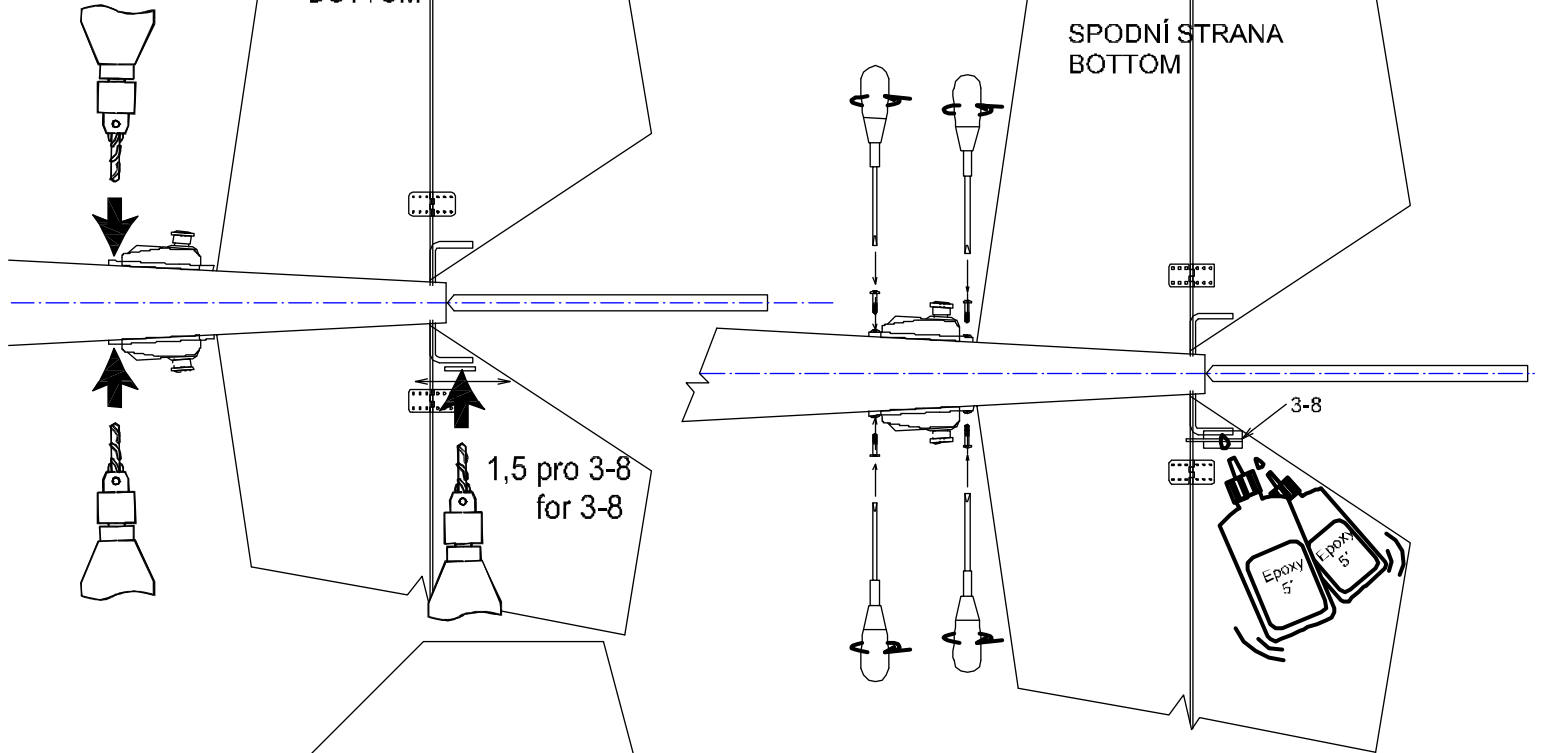

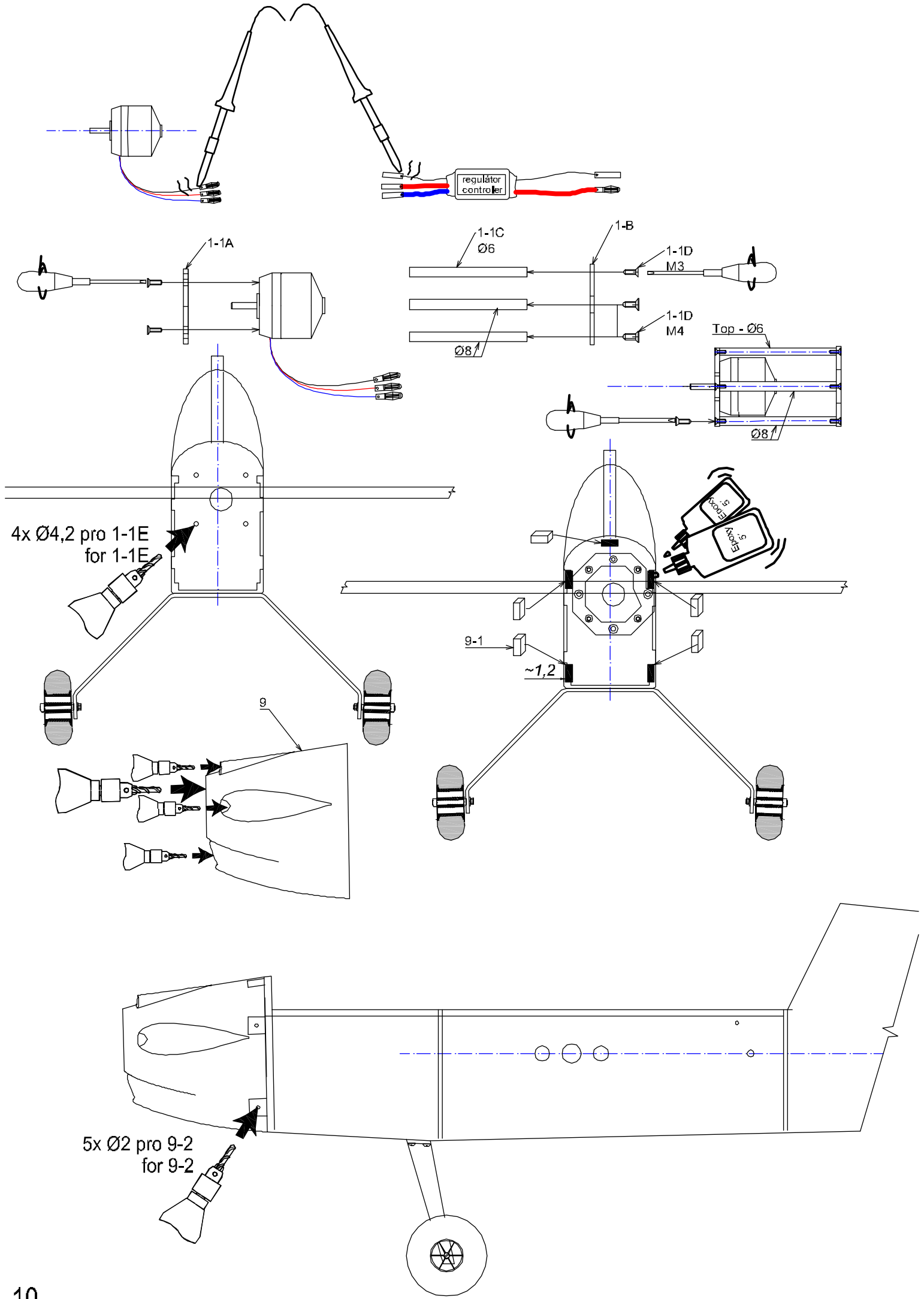

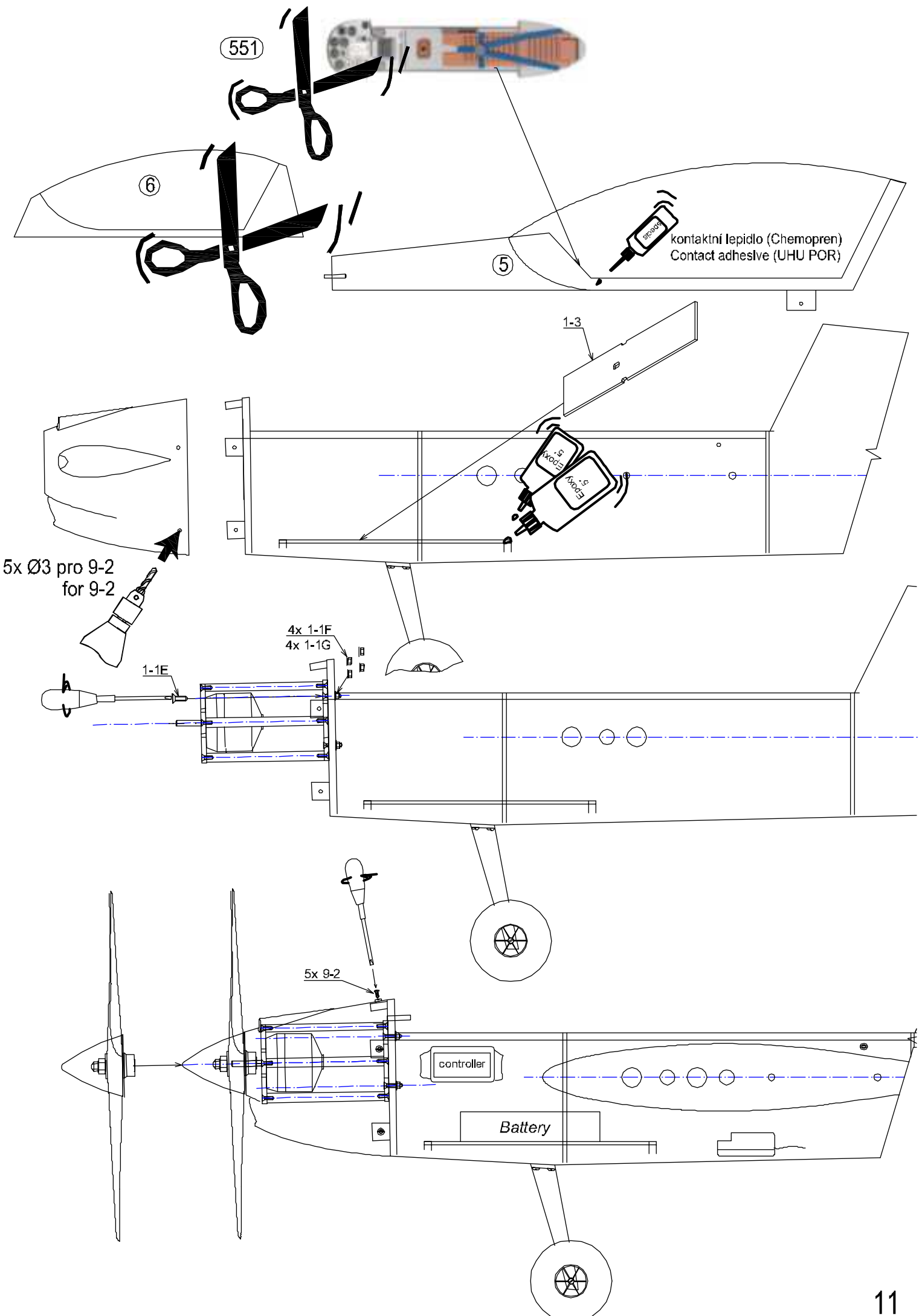

551

6

5

kontaktní lepidlo (Chemopren)
Contact adhesive (UHU POR)

1-3

5x Ø3 pro 9-2
for 9-2

1-1E

4x 1-1F
4x 1-1G

5x 9-2

controller

Battery

FOR GLOW ENGINE

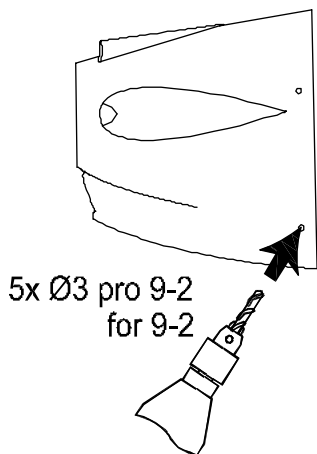
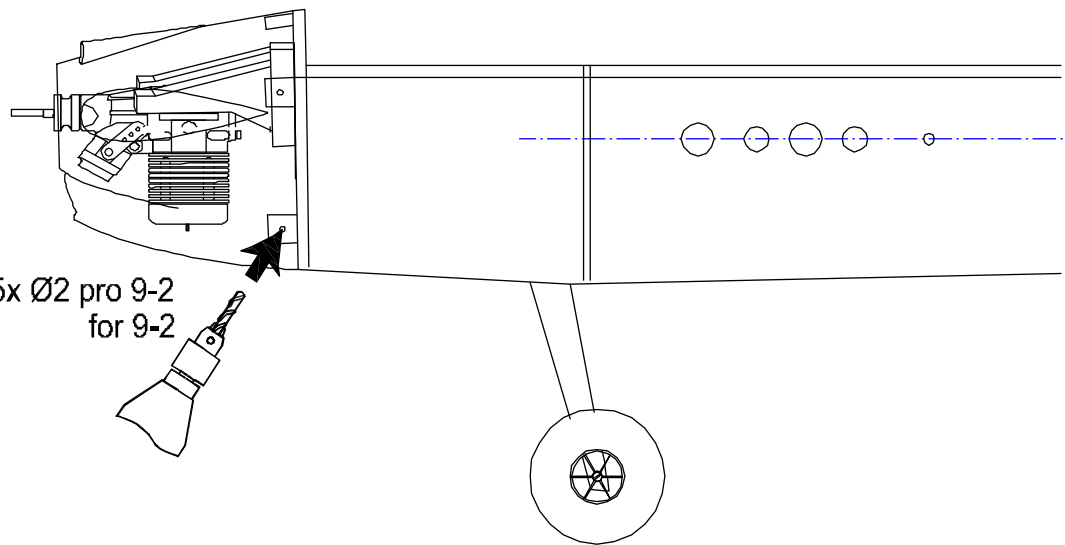
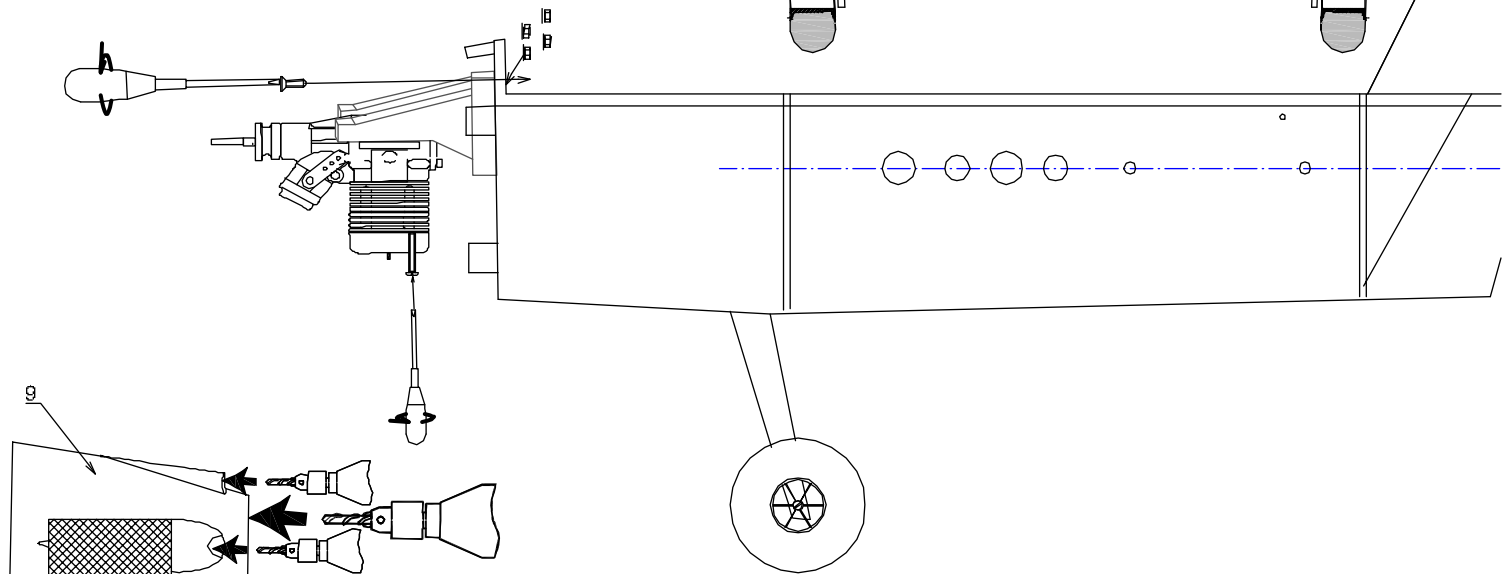
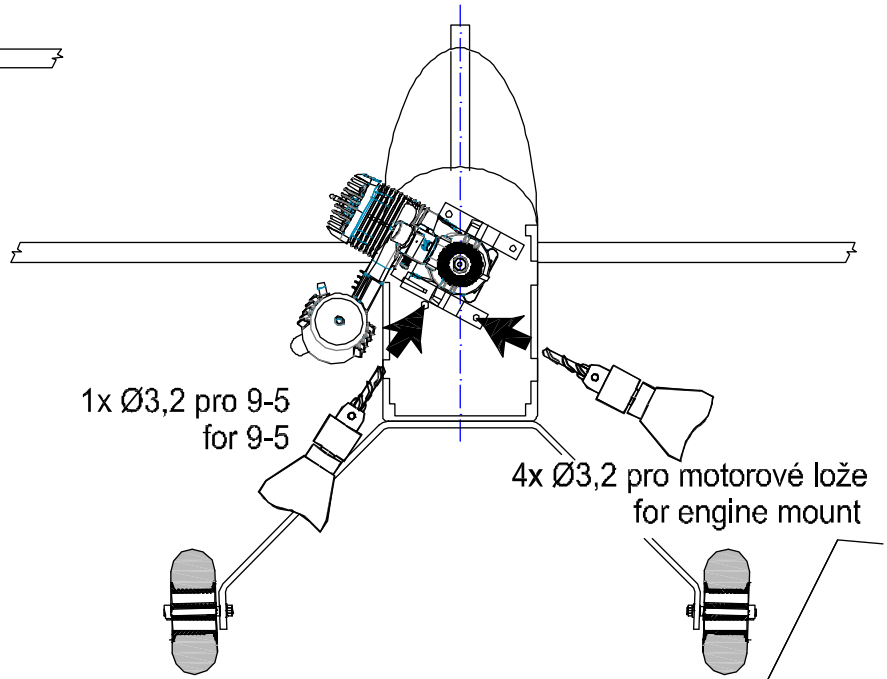
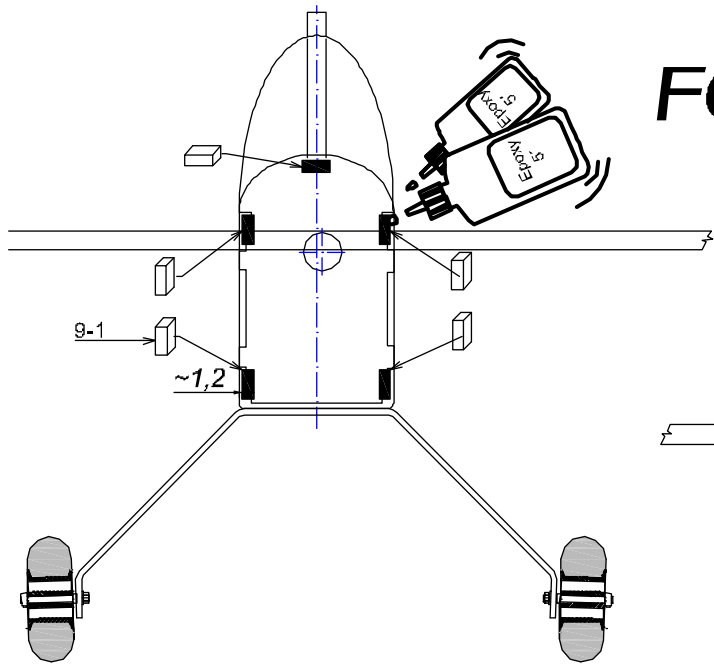

FOR GLOW ENGINE

