

ELECTRO SAILPLANE

# Fascination



Manufactured by:

**TOPMODEL CZ**

679 05 HABRŮVKA 100 - CZECH REPUBLIC

[www.topmodelcz.com](http://www.topmodelcz.com)

e-mail: [info@topmodelcz.cz](mailto:info@topmodelcz.cz)

Order N°: 02075.D2

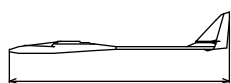

1535mm

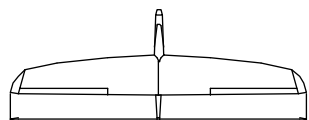

3600mm

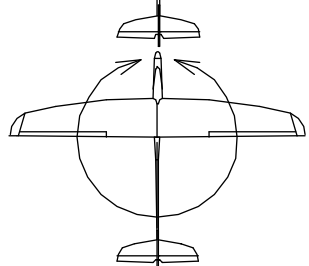

76,7dm<sup>2</sup>  
37,8-41,7g/dm<sup>2</sup>



2,9 - 3,2kg



MH 32

*Není-li uvedeno jinak, všechny  
neoznačené míry jsou v milimetrech*  
UNLES STATED, ALL DIMENSIONS  
ARE IN MILIMETERS

Radio system you'll need :

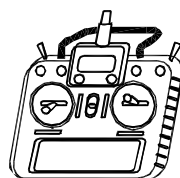

5channel  
with  
6 servos

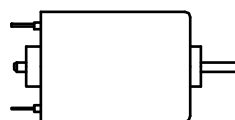

Mega ACn22/45/3E

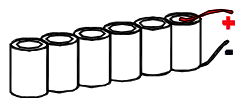

4S Lixx 3-3,6Ah

Part #	Part name	Material, dimensions	Loose	In bag
	building instruction		01	-
1	fuselage	fibreglass	01	-
1-1	engine mount	fibreglass 3 mm	-	01
1-2	servo tray	plywood 4 x 47 x 50 mm	-	01
1-21	servo mount	polyurethan	-	02
2	wing	foam core-balsa	03	-
2-1	aileron	foam core-balsa	02	-
2-11	flap	foam core-balsa	02	-
24	wing joiner	fibreglass Ø 8 x 155 mm	-	02
2-2	wing fixing screw	screw M 5 x 20 mm	-	02
2-21	centering pin	fibreglass Ø 3 x 25 mm	-	02
2-25	centering pin	fibreglass Ø 6 x 65 mm	-	01
2-3	nut	M5	-	02
2-31	nut mount	plywood 3 x 23 x 53 mm	-	01
2-4	servo mount	polyurethan 13mm	-	08
2-41	wing servo cover	ABS plastic	-	04
2-5	aileron-flap pushrod	piano wire M2	-	04
2-6	clevis	MPJ 2110	-	04
2-8	aileron horn	fibreglass plate 1,5 mm	-	02
2-81	flap horn	fibreglass plate 1,5 mm	-	02
3	horizontal stabilizer	balsa assembly	02	-
3-21	centering pin	fibreglass Ø 3 x 70 mm	-	01
3-3	elevator joiner	fibreglass Ø 4 x 150 mm	-	01
3-41	elevator servo cover	sticker Ø 50 mm	-	01
3-5	elevator link	piano wire M2 L= 60mm	-	01
3-6	clevis	MPJ 2110, nut M2, MPJ 2406	-	01+01+01
3-8	elevator horn	plastic	-	01
4	fin	balsa assembly	01	-
4-11	exit rudder control	plastic Ø 3/2 x 40mm	-	02
4-3	closing strip	balsa 5 mm	-	01
4-5	rudder link	cable set	-	01
4-6	clevis	MPJ 2110	-	02
4-7	cable coupler	MPJ 2050	-	02
4-8	rudder horn	fibreglass plate 1,5 mm	-	02
6	canopy	fibreglass	01	-
6-2	canopy fixing	wood screw Ø2,9x6,5 mm	-	01
7	stickers		02	
11	pinned hinge	MPJ 2502	-	03

**RECOMMENDED EQUIPMENT:**

Radio : 5 channel + 7 channel (receiver)  
 Servos : 6x HS 82MG  
 Motor : MEGA ACn 22/45/3E  
 Controller: 40 - 60A ( JETI SPIN44 - 66, Xreg 60 with switch BEC )  
 Spinner: TURBO ø 40 mm - order No.0201559  
 Prop: Aeronaut CAM Carbon 13/6,5"  
 Battery: LiPo 14,8V/ 3 - 4,5Ah  
 Twisted cable - Large- ~ 2,7 m  
 Shrink insulation 1.6mm- ~ 0,6 m  
 Connector MPX 6 plug + socket - 2 pair  
 Connector CANON 15 - 1 pair

**ATTENTION:**

This model construction kit is not a toy and is not suitable for children under the age of 14. Incorrect use of this material could cause material damage or person injury. You are fully responsible for your actions when you use this model. Fly at a safe distance from occupied zones. Be sure that no one else is using the same frequency as you.

**Before first take-off check up please if model aeroplane parts aren't crooked. The reparation is possible through the use of hot-air dryer.**

Položka	Název dílu	Materiál, rozměr	Volně/ks	Balíček/ks
	montážní návod		01	-
1	trup	laminát	01	-
1-1	motorová přepážka	sklotextit 3 mm	-	01
1-2	držák serva ocasních ploch	překližka 4 x 47 x 50 mm	-	01
1-21	držák serva VOP	polyuretan 13mm	-	02
2	křídlo	polystyren - balsa	03	-
2-1	křídélko	polystyren - balsa	02	-
2-11	vztlaková klapka	polystyren - balsa	02	-
24	spojka křídla	laminát Ø 8 x 155 mm	-	02
2-2	uchycení křídla	šroub M 5 x 20 mm	-	02
2-21	aretační kolík	laminát Ø 3 x 25 mm	-	02
2-25	aretační kolík	laminát Ø 6 x 65 mm	-	01
2-3	uchycení křídla	matice M5	-	02
2-31	podložka matice	překližka 3 x 23 x 53	-	01
2-4	držák serva	polyuretan 13mm	-	08
2-41	krytka serva	ABS folie	-	04
2-5	táhlo křídélka a klapky	ocel	-	04
2-6	koncovka táhla	MPJ 2110	-	04
2-8	páka křídélka	sklotextit 1,5 mm	-	02
2-81	páka klapky	sklotextit 1,5 mm	-	02
3	VOP	balsa konstrukční	02	-
3-21	aretační kolík	laminát Ø3mm L = 70mm	-	01
3-3	spojka VOP	laminát Ø4mm L = 150mm	-	01
3-41	krytka serva VOP	samolepka Ø 50 mm	-	01
3-5	táhlo VOP	ocel M 2mm L = 60 mm	-	01
3-6	koncovka táhla	MPJ 2110, matice M2, MPJ 2406	-	01+01+01
3-8	páka	plast	-	01
4	směrovka	balsa konstrukční	01	-
4-11	průchodka táhla	plast Ø3/2mm L = 40mm	-	02
4-3	steven	balsa 6	-	01
4-5	lanko směrovky	MPJ 2302	-	01
4-6	koncovka táhla	MPJ 2110	-	02
4-7	spojka lanka	MPJ 2050	-	02
4-8	páka směrovky	sklotextit 1,5 mm	-	02
6	kabina	laminát	01	-
6-2	uchycení kabiny	vrut Ø2,9x6,5	-	01
7	obtisky		02	-
11	závěsy kormidel	MPJ 2502	-	03

#### DOPORUČENÉ PŘÍSLUŠENSTVÍ :

RC souprava : 5 kanál + 7 kanál přijímač  
 Serva : 6x HS 82MG  
 Motor : MEGA Acn 22/45/3E  
 Regulátor: 40-60A ( např. SPIN 44, XReg60 )  
 Kužel: TURBO Ø40mm - [0201559](#)  
 Listy: Aeronaut CAM Carbon 13/6,5“  
 Aku: 4S LiPol 3,2-4,5Ah, 12 - 14článků Nixx  
 Kroucený kabel – cca 2,7 m  
 Smršťovací bužírka Ø 1,6 mm – cca 0,6 m  
 Konektor MPX 6 – 2 páry  
 Konektor CANON 15 – 1 pár

**Před prvním startem zkontrolujte jestli nejsou díly modelu zkroucené.  
 Náprava je možná pomocí horkovzdušné pistole .**

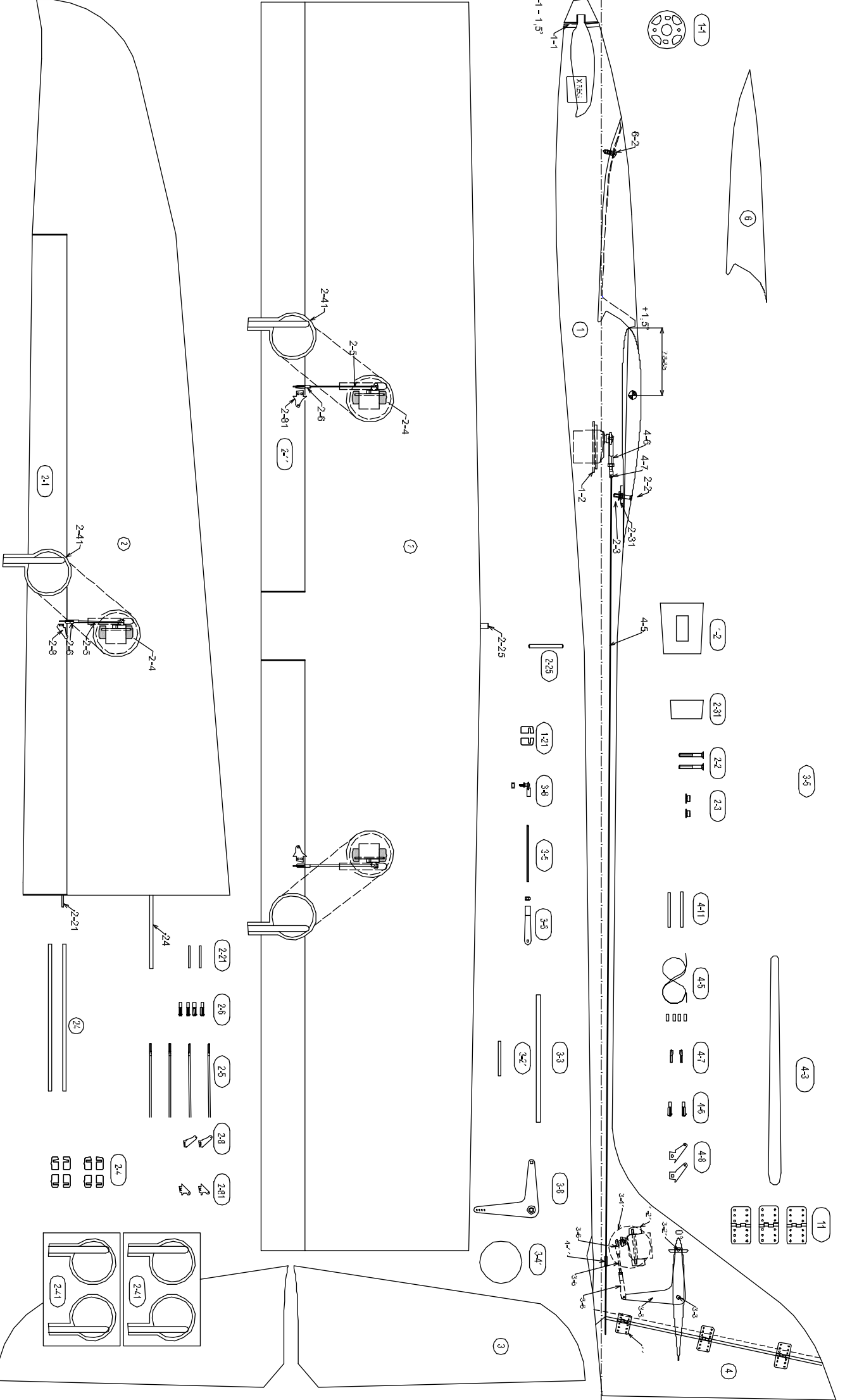

# Fascination

© VII 2010 TOPMODEL CZ Manufactured by TOPMODEL CZ s.r.o. 679 05 HABRŮVKA 100 - Better made in the Czech Republic  
 www.topmodelcz.com e-mail: info@topmodelcz.cz

Oracover®  
pro 2-25  
for 2-25

SPODNÍ STRANA  
BOTTOM

2

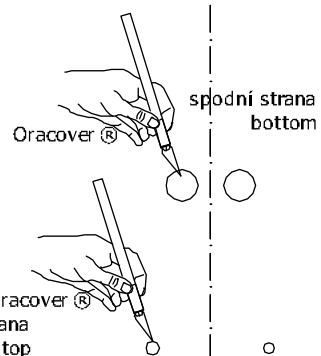
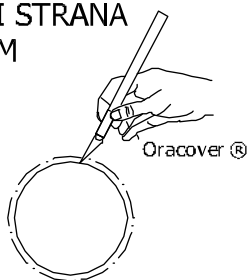

spodní + horní strana  
bottom + top

SPODNÍ STRANA  
BOTTOM

2

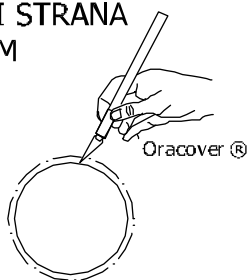

SPODNÍ STRANA  
BOTTOM

2

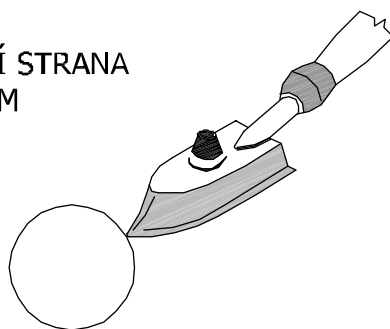

SPODNÍ STRANA  
BOTTOM



SPODNÍ STRANA  
BOTTOM

2

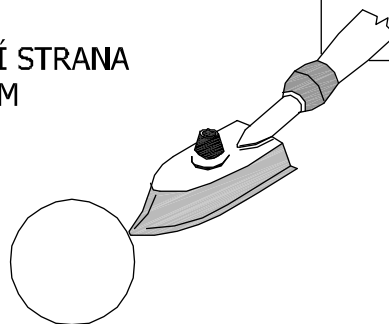

2

### SPODNÍ STRANA BOTTOM

krok 1.  
step 1.

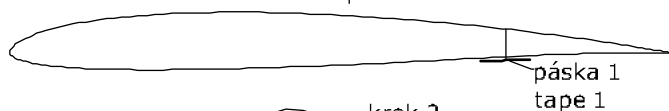

krok 2.  
step 2.



2-11

1/2  
1/2

2

### VRCHNÍ STRANA TOP

krok 1.  
step 1.



krok 2.  
step 2.

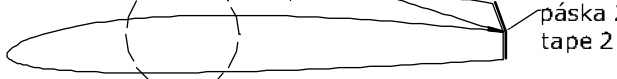

1/2  
1/2

2-1

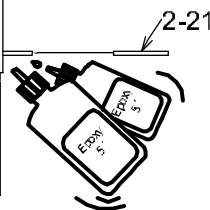
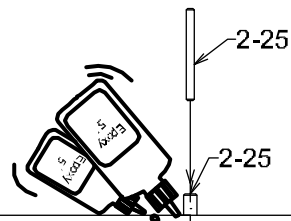

2

pro servo klapek  
for flaps servo

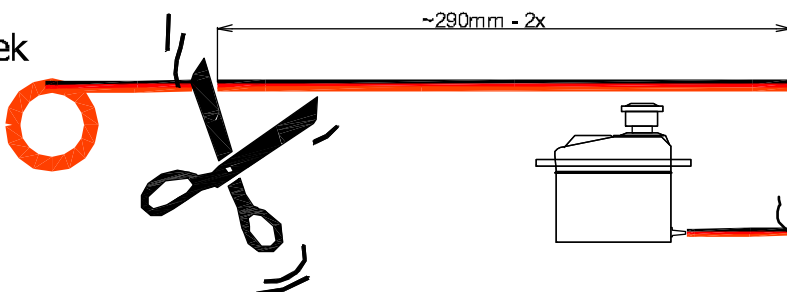

pro servo křidélek  
for aileron servo

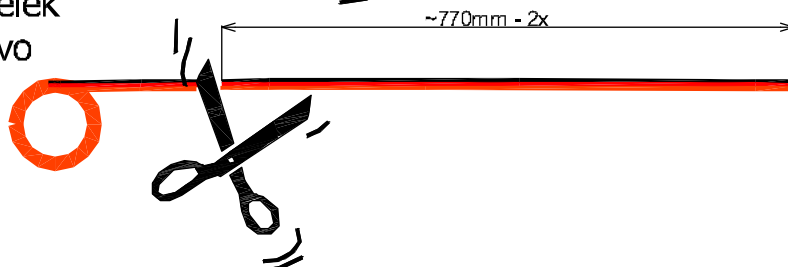

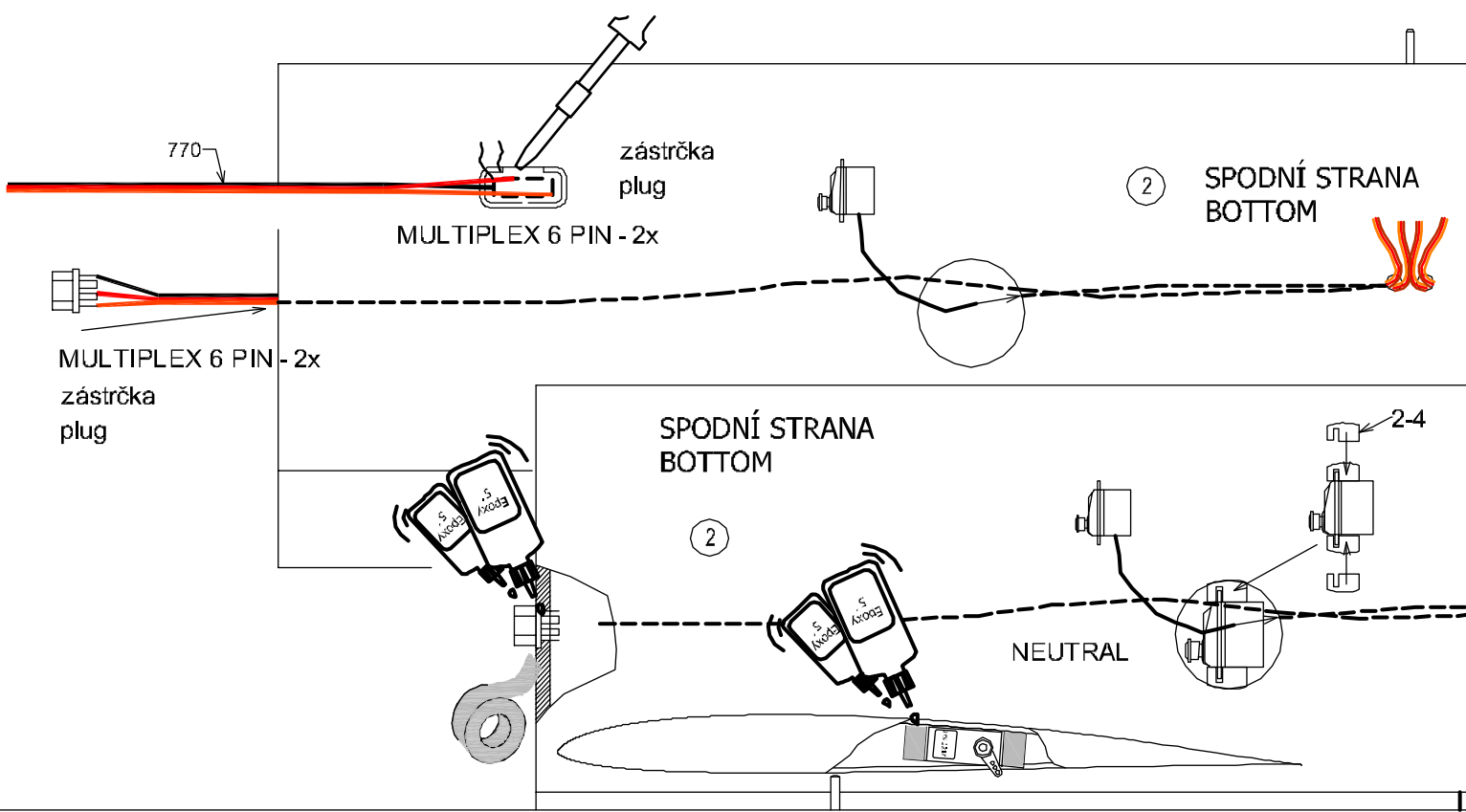

SPODNÍ STRANA BOTTOM

2

Ø1,5 pro 2-81  
Ø1,5 for 2-81

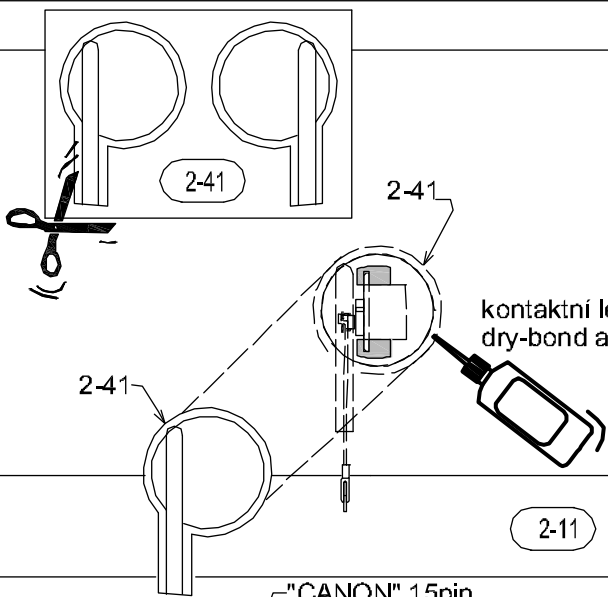
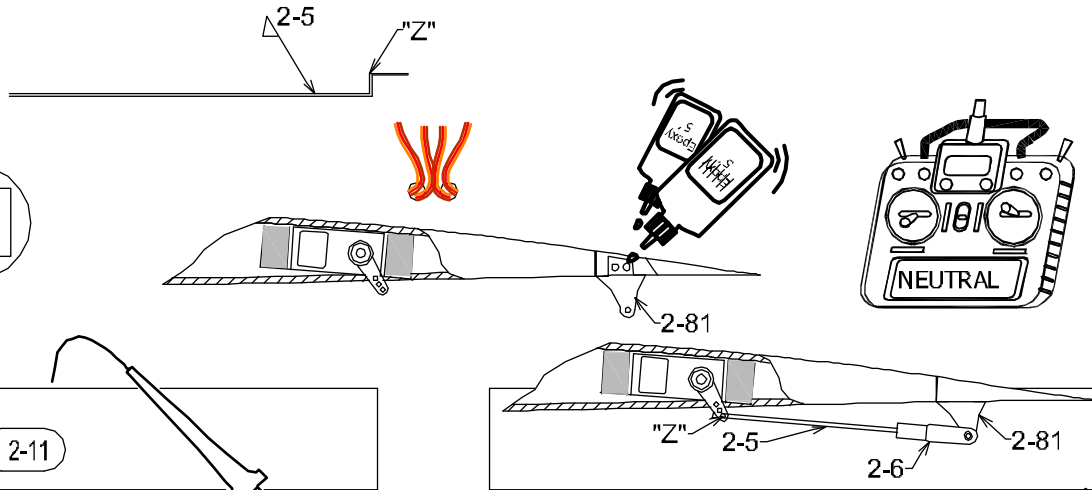

SPODNÍ STRANA BOTTOM

2

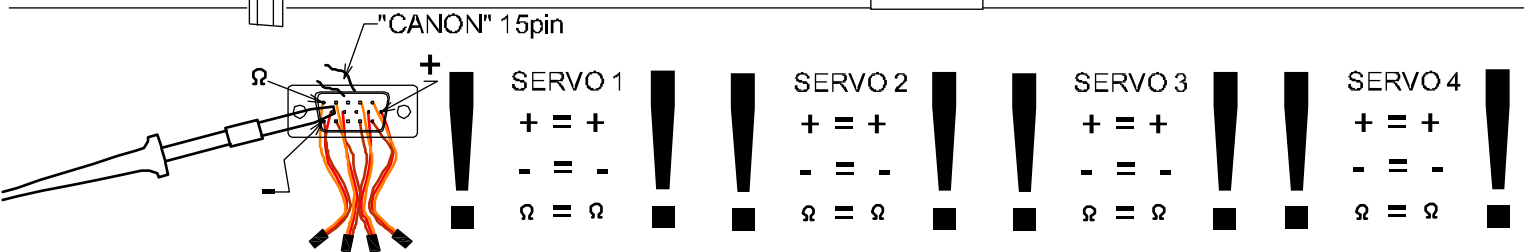

pro servo křidélek  
for aileron servo

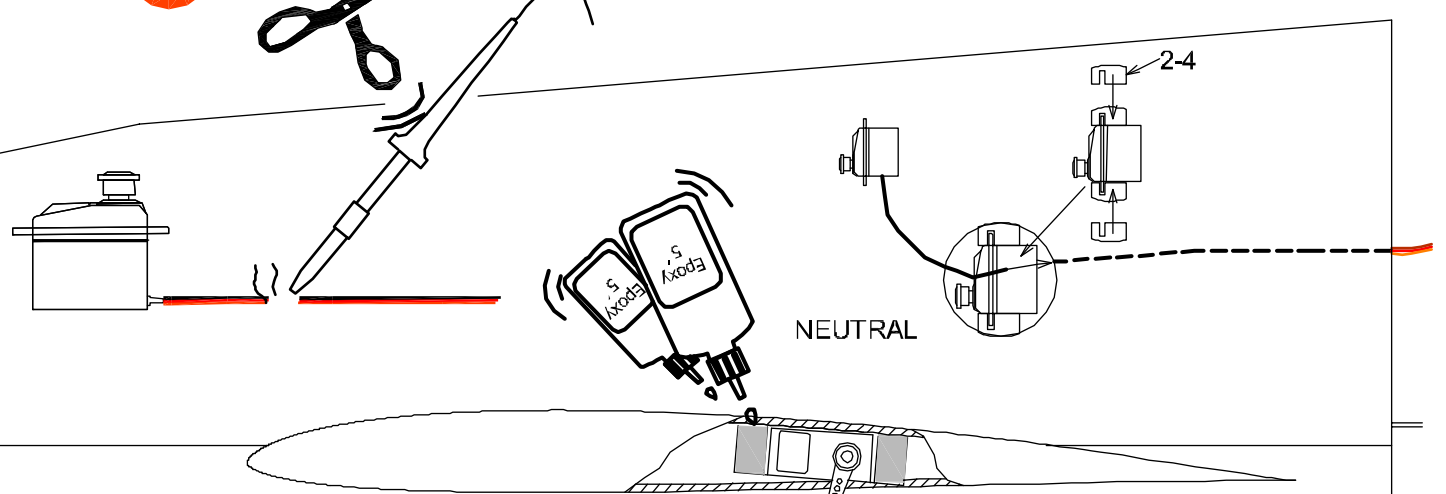

SPODNÍ STRANA  
BOTTOM

2

Ø1,5 pro 2-81  
Ø1,5 for 2-81

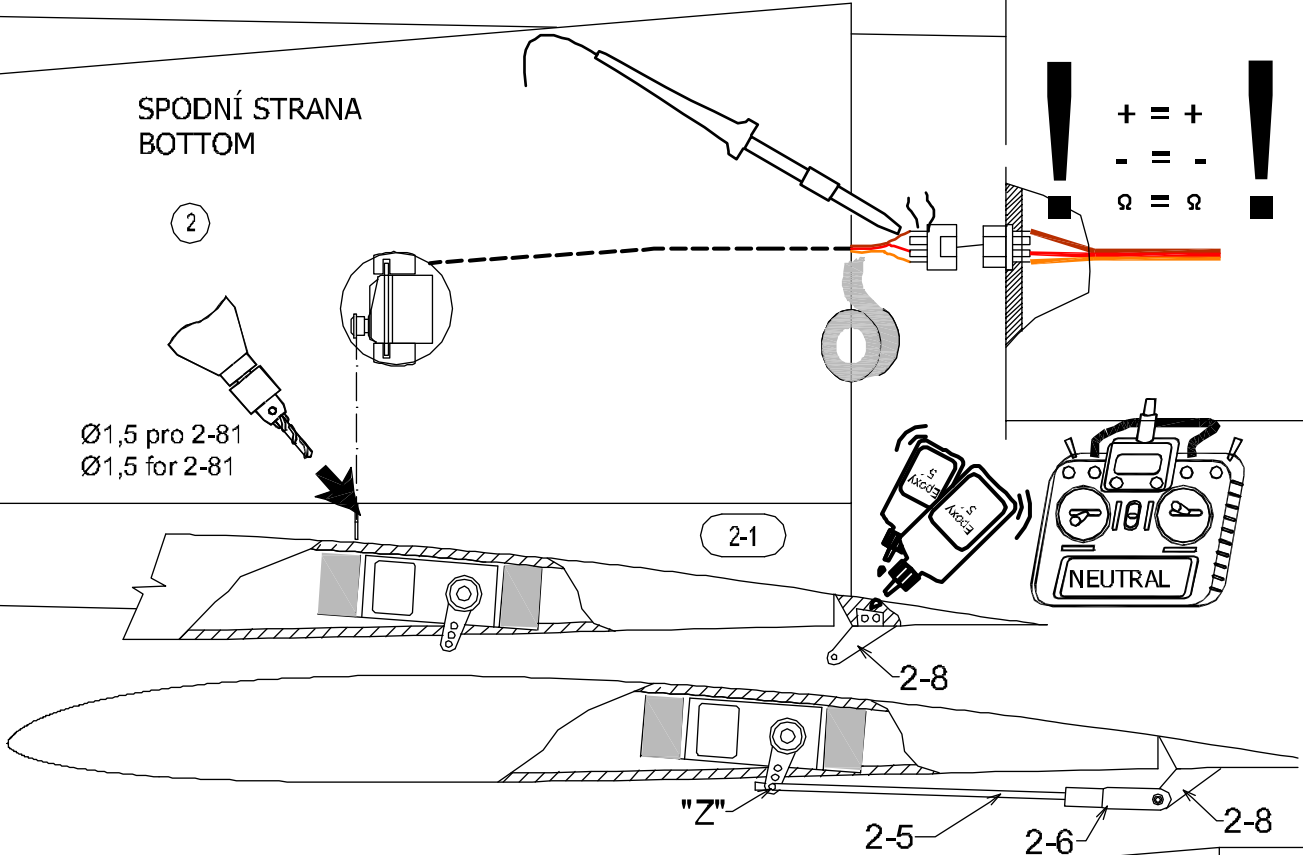
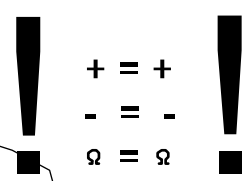

SPODNÍ STRANA  
BOTTOM

2

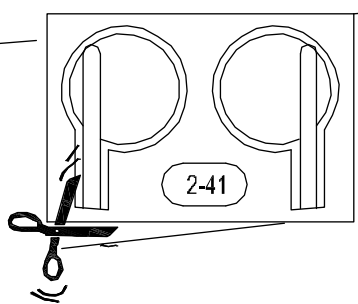

2-41

kontaktní lepidlo (Chemopren)  
dry-bond adhesive (UHU-POR)

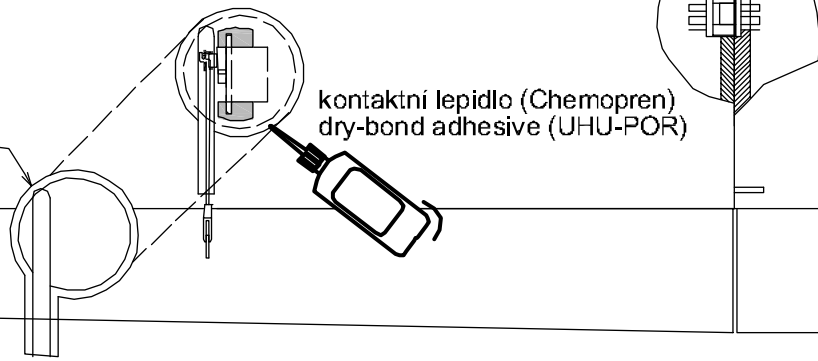



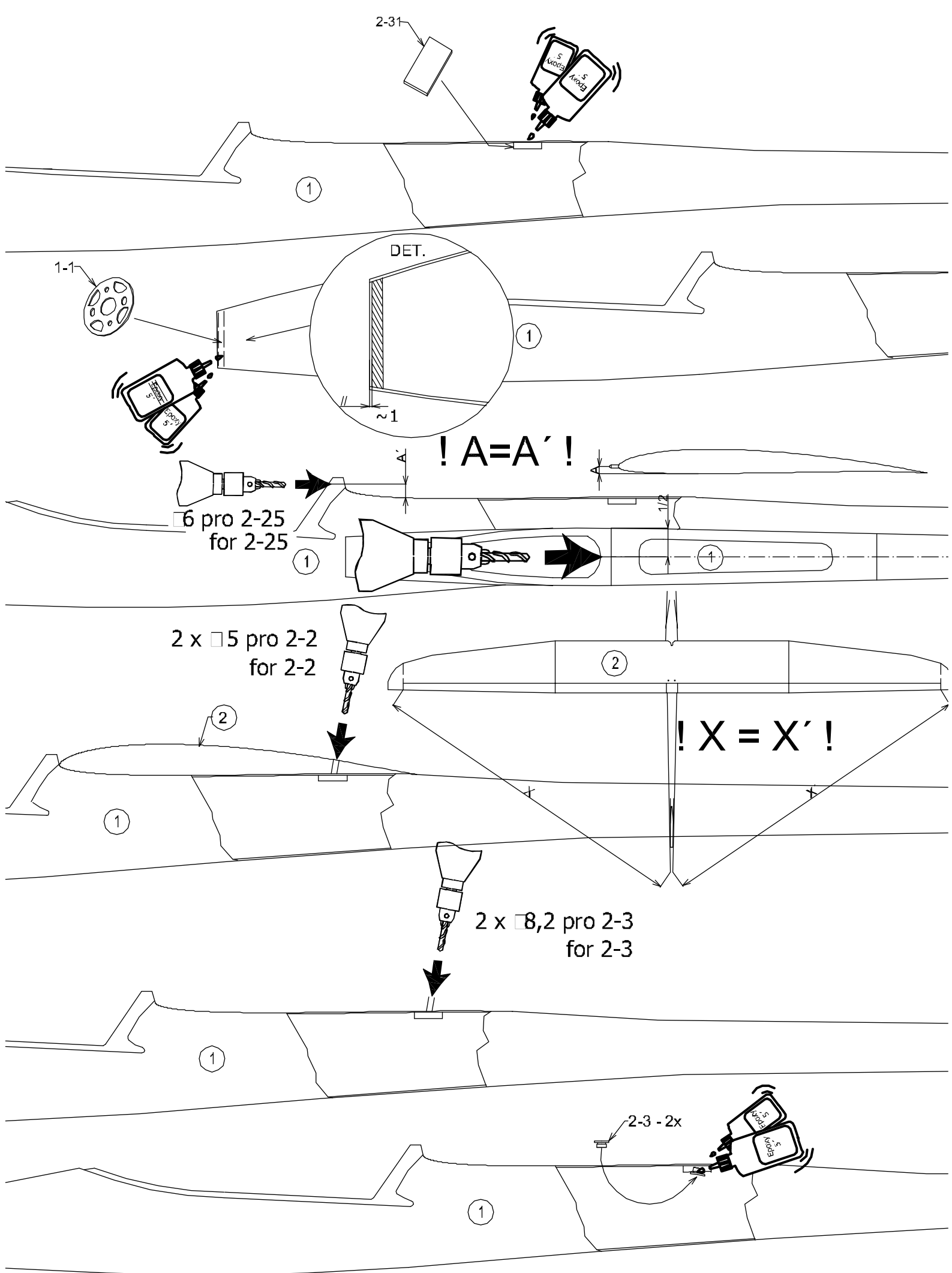

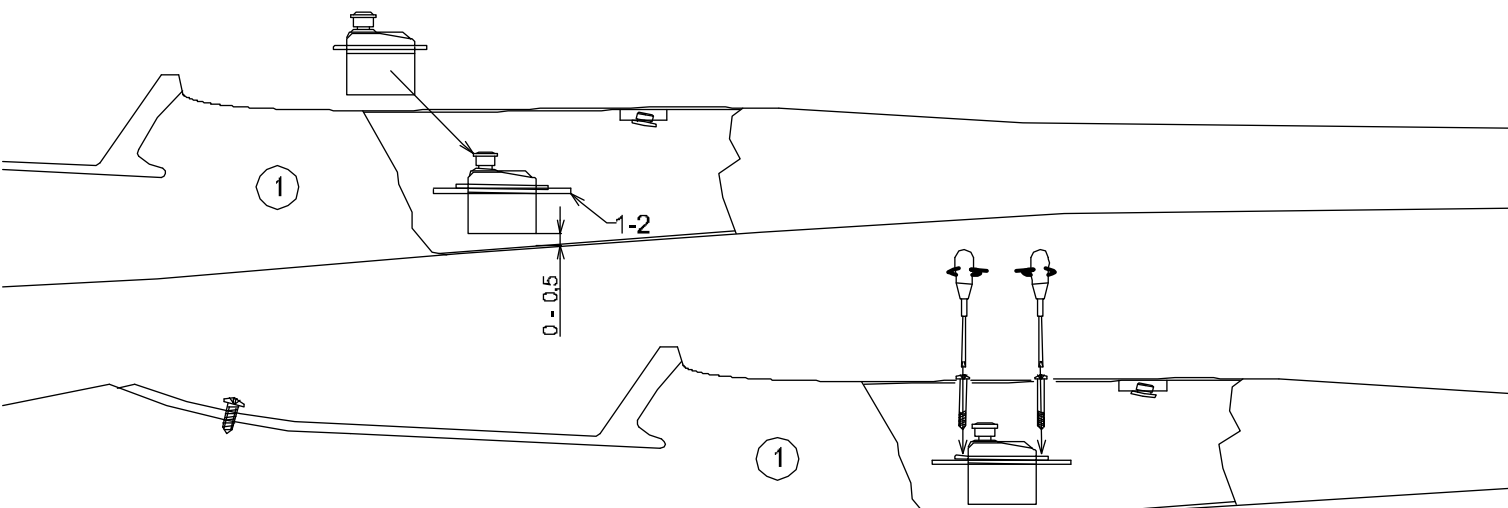
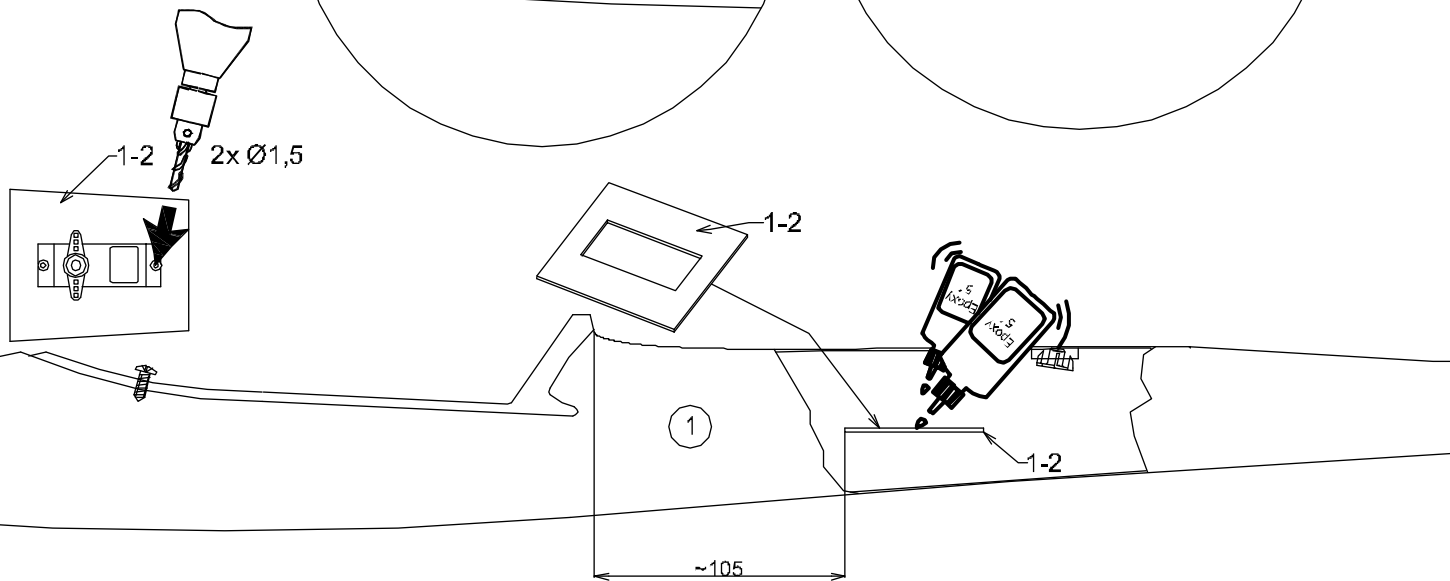
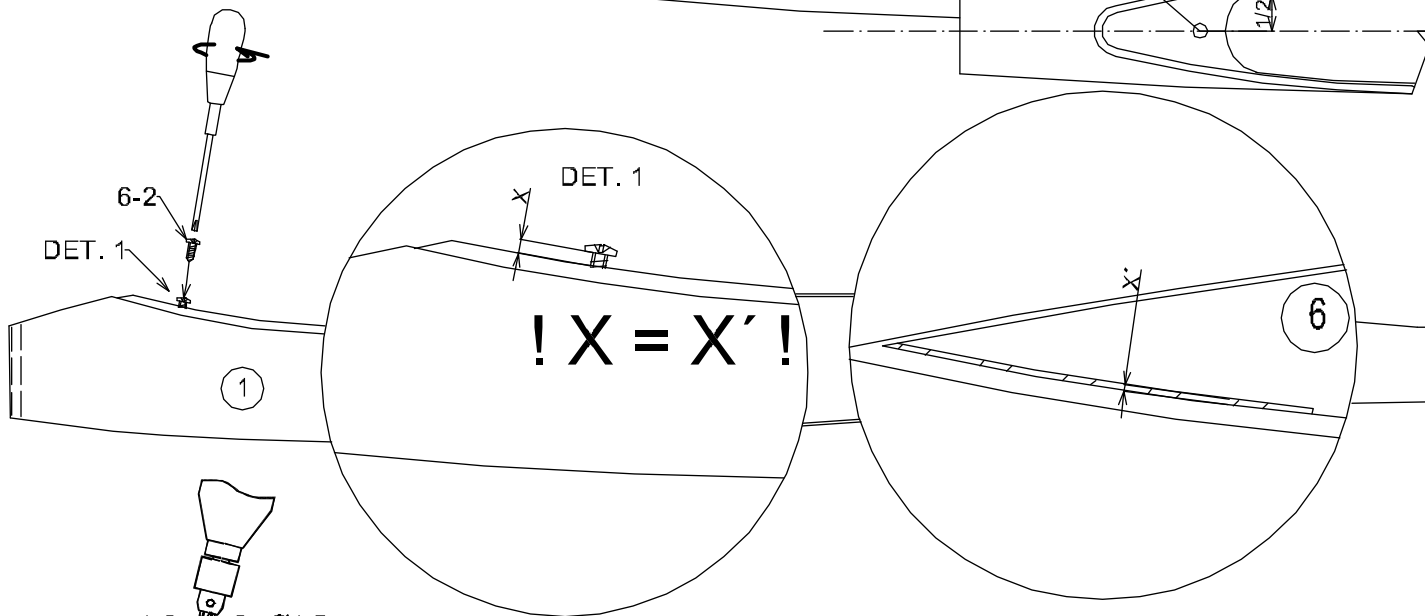
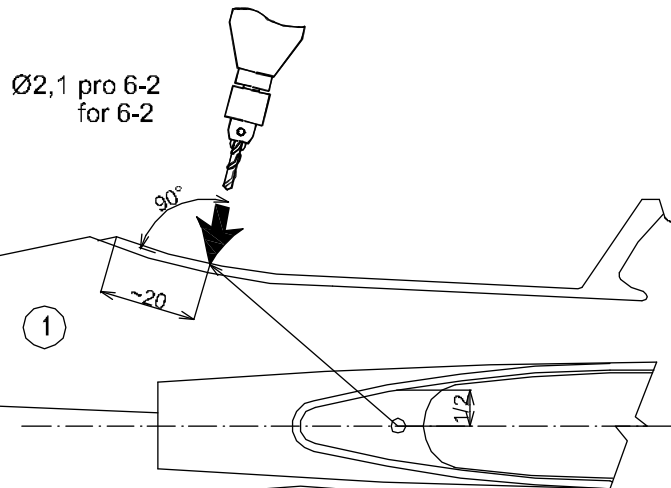
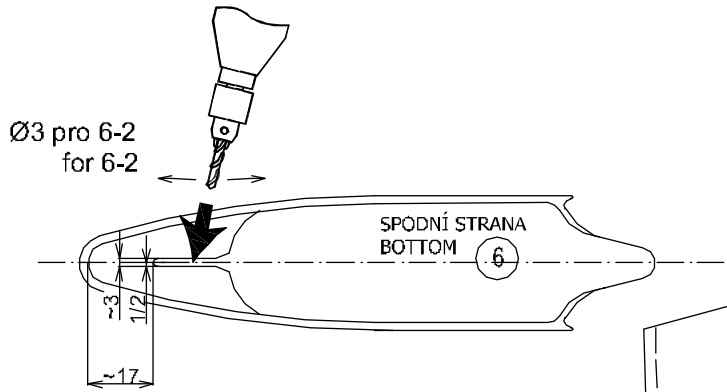

servo výškovky  
elevator servo

pro servo výškovky  
for elevator servo

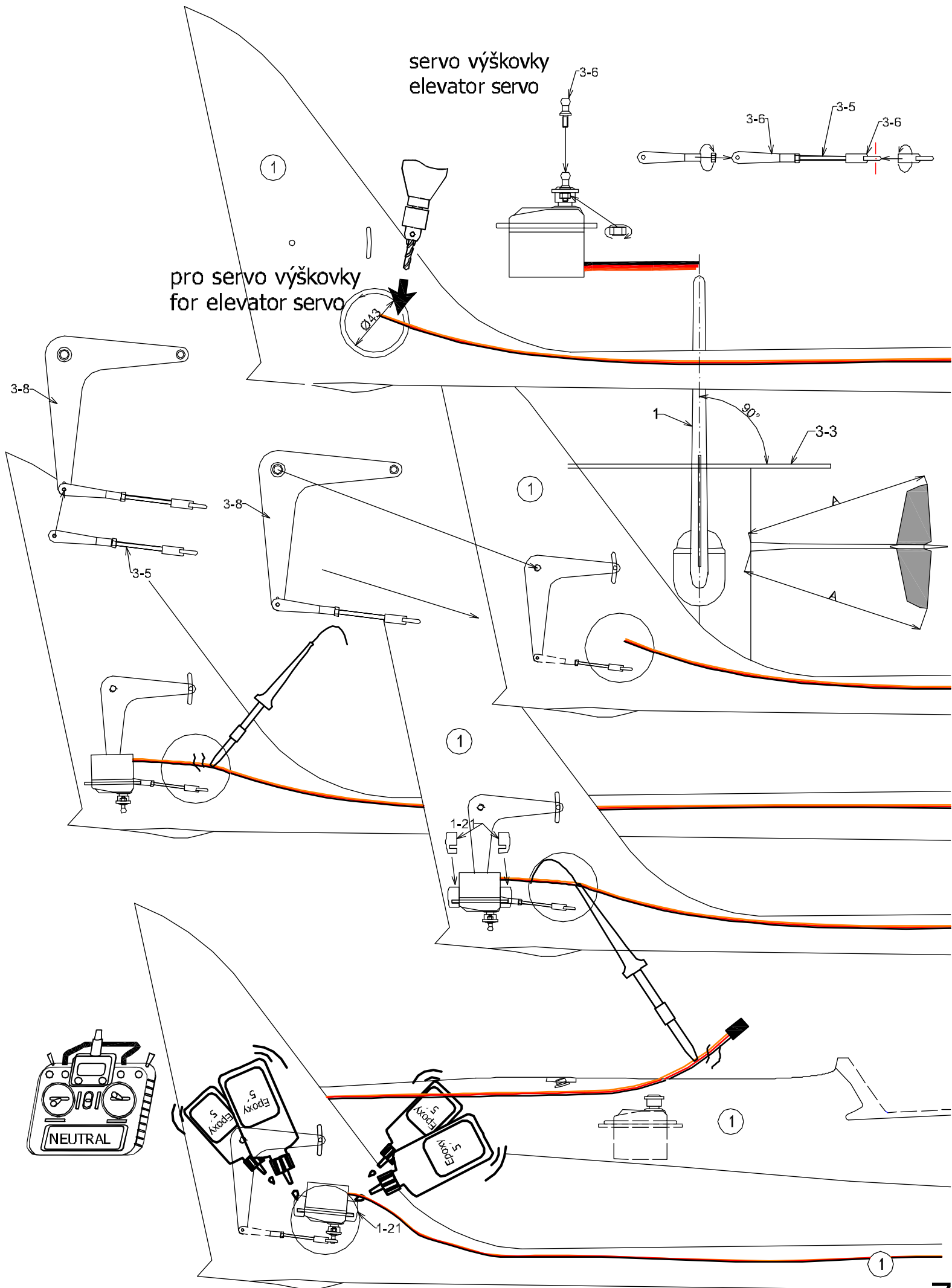

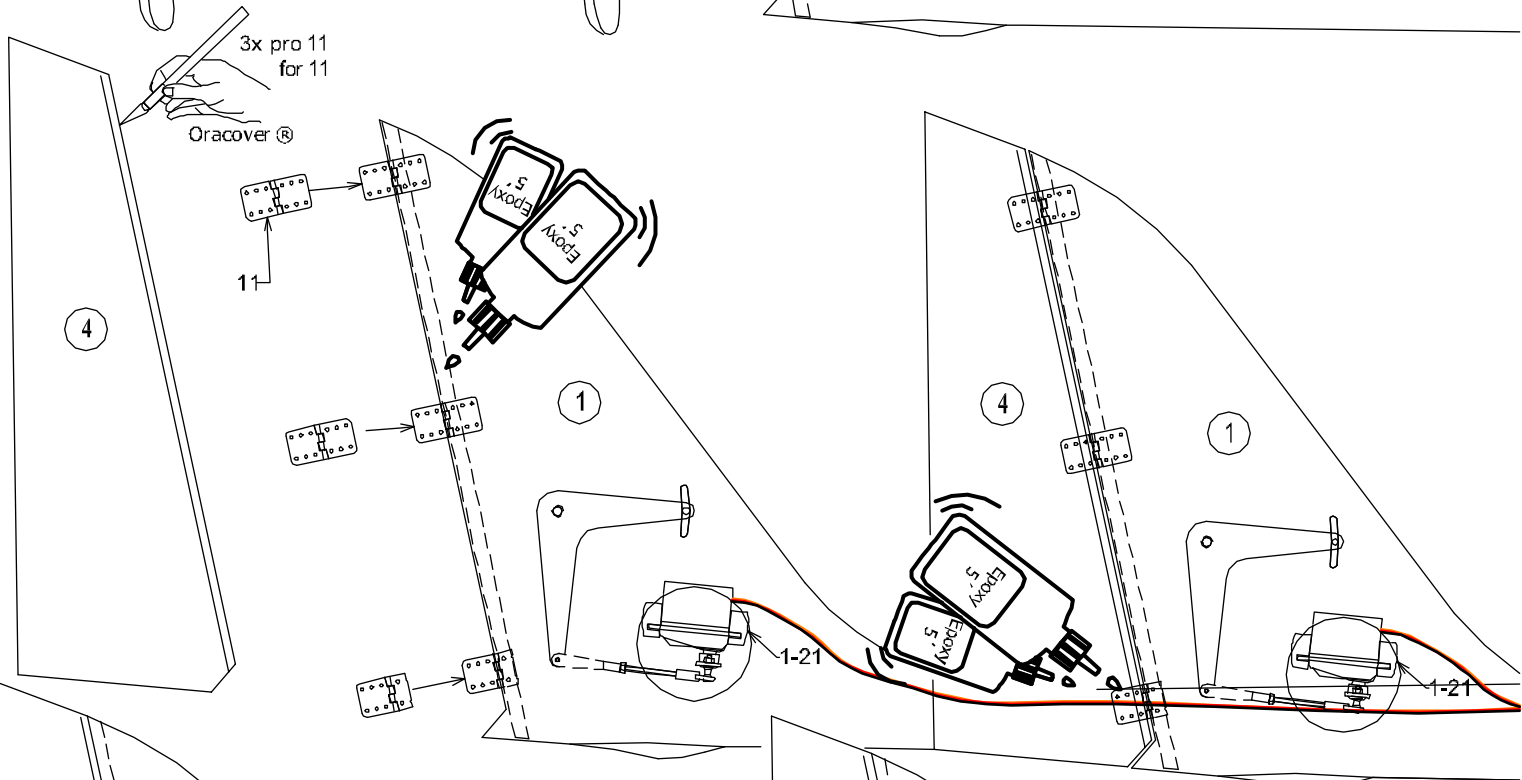
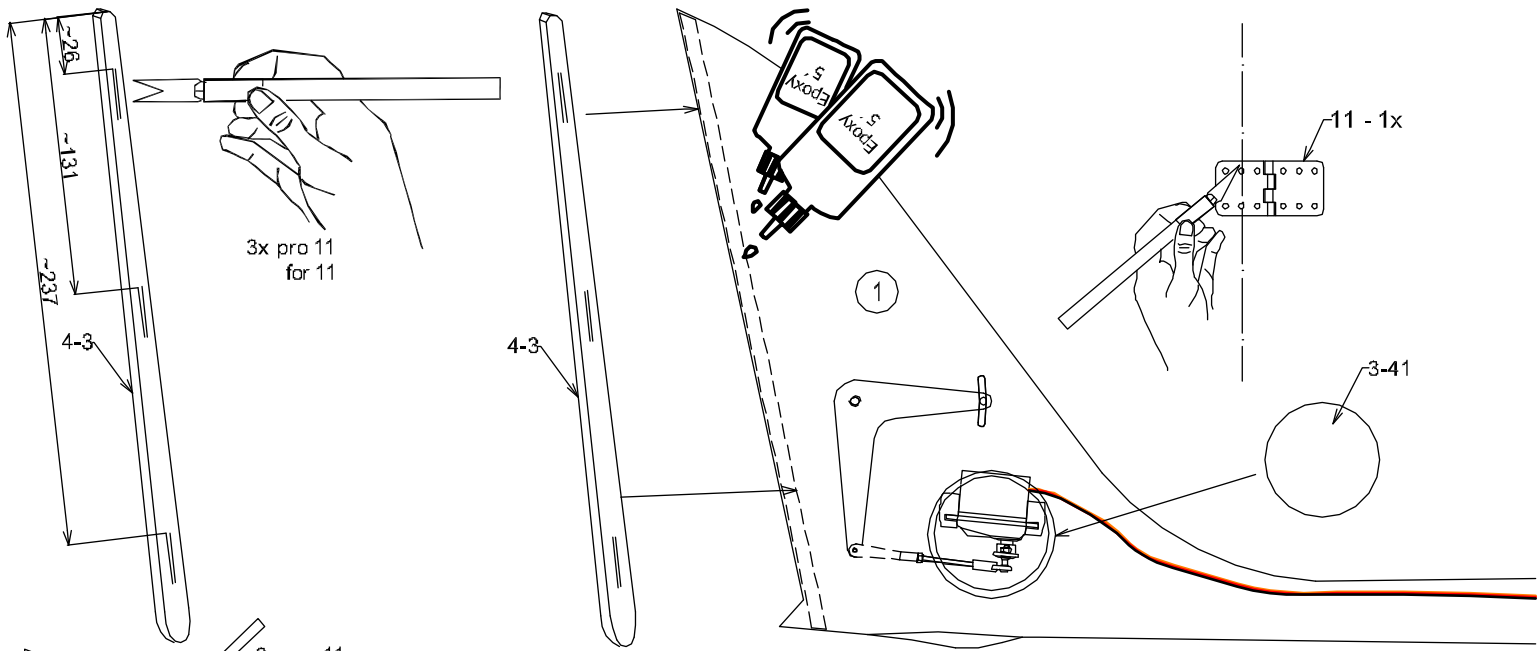

*levá i pravá strana trupu:*  
*left side and right side:*

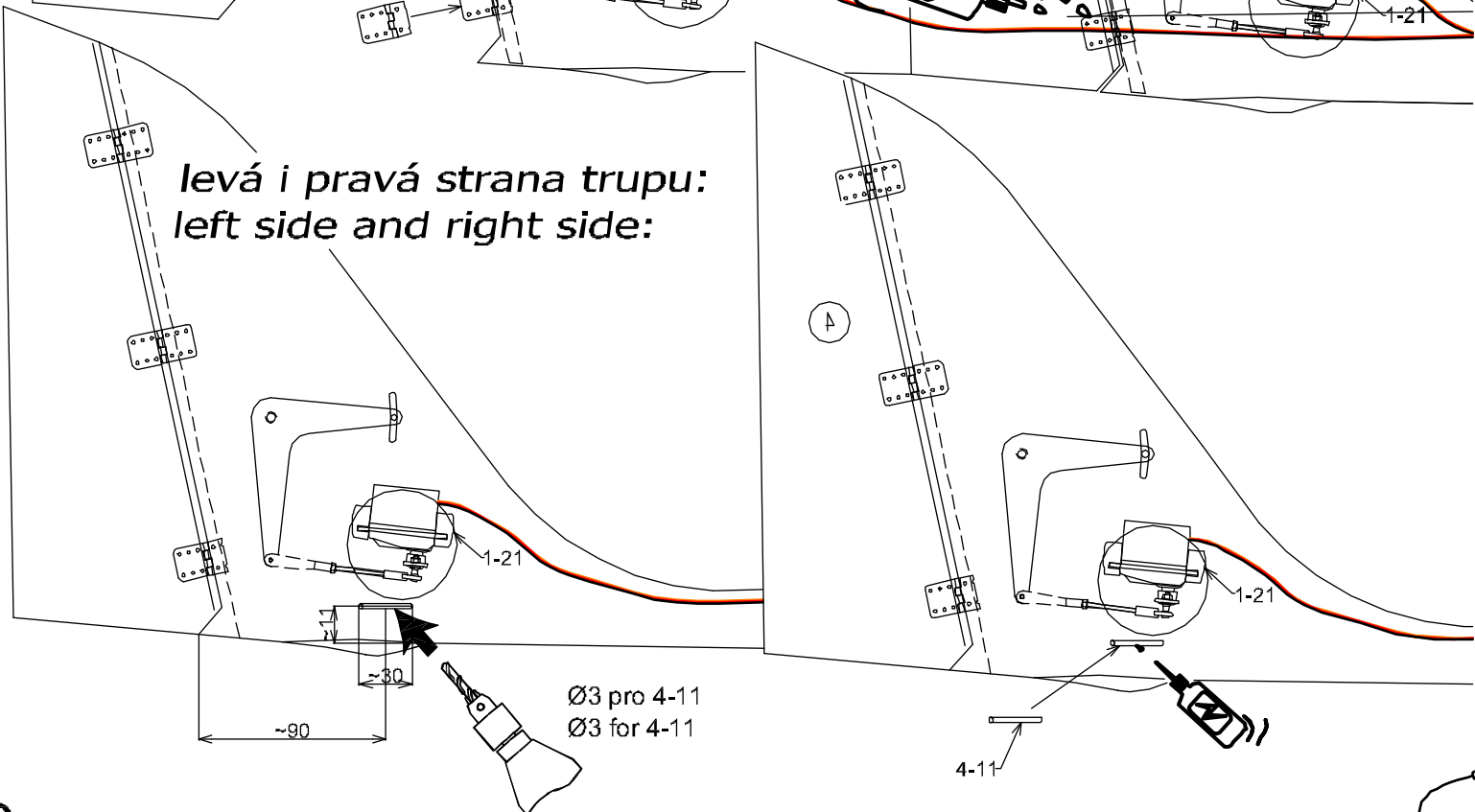

levá i pravá strana trupu:  
left side and right side:

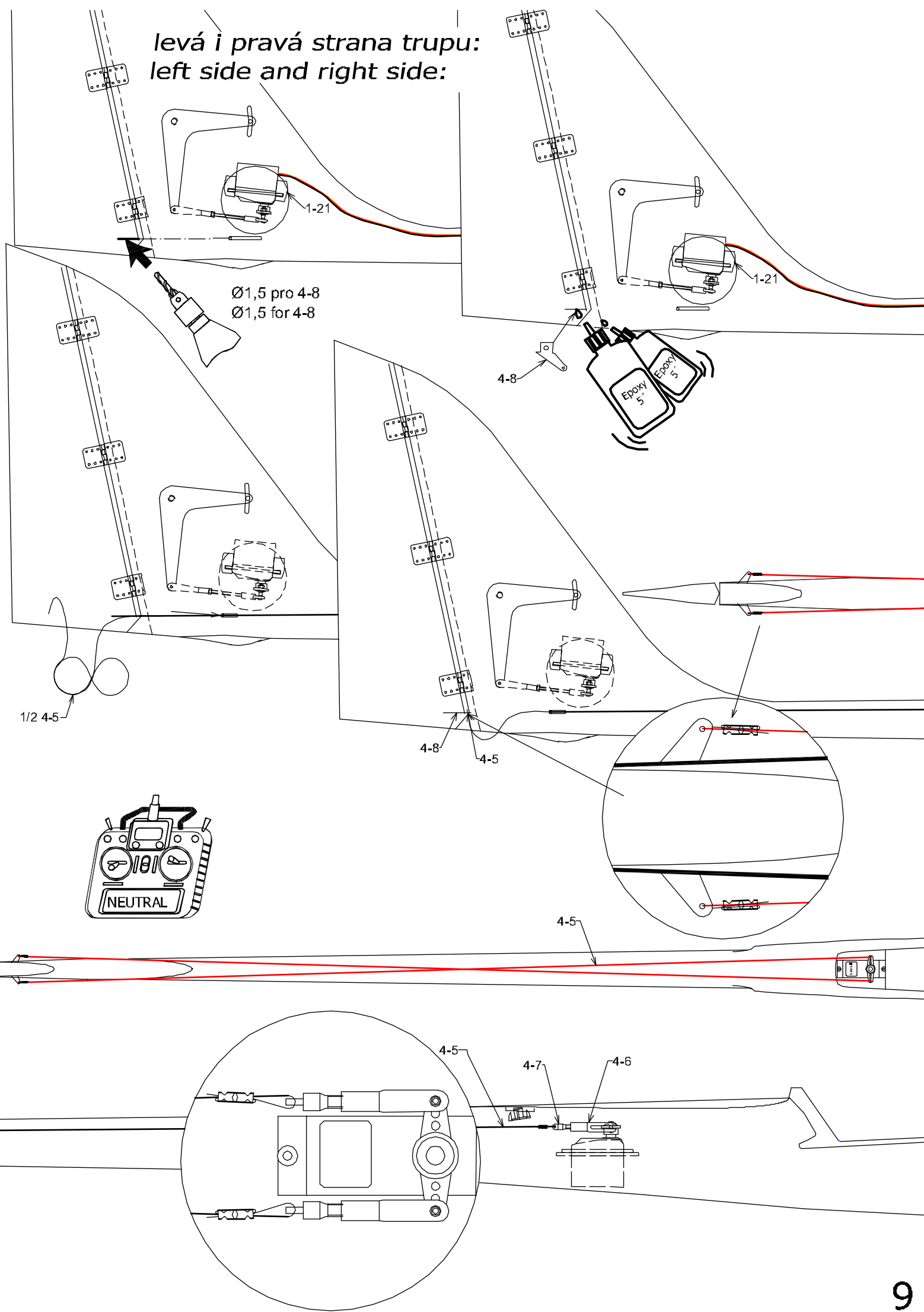

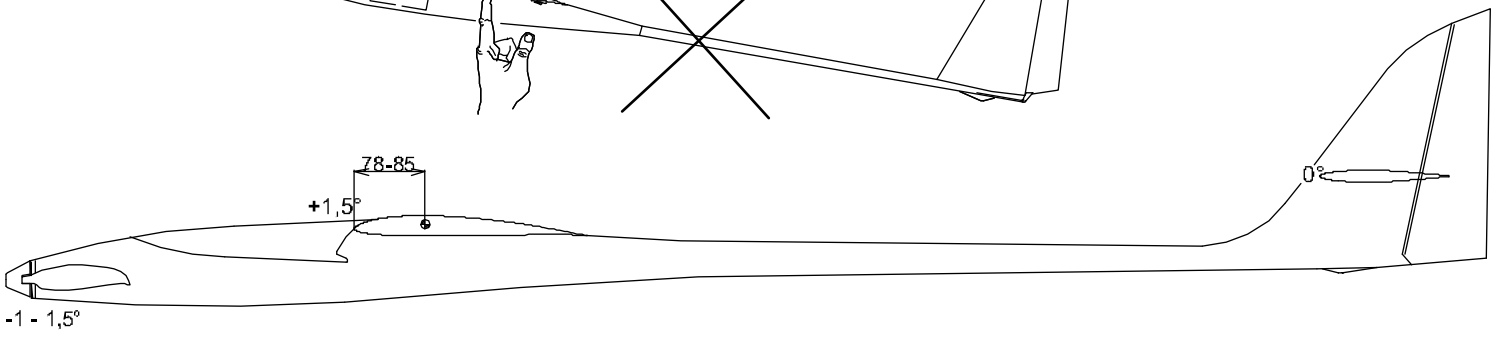
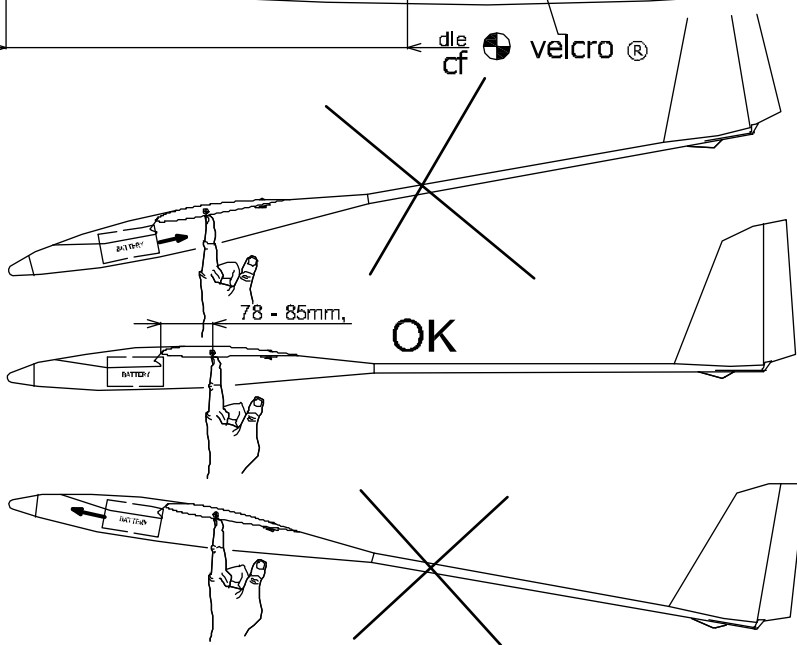
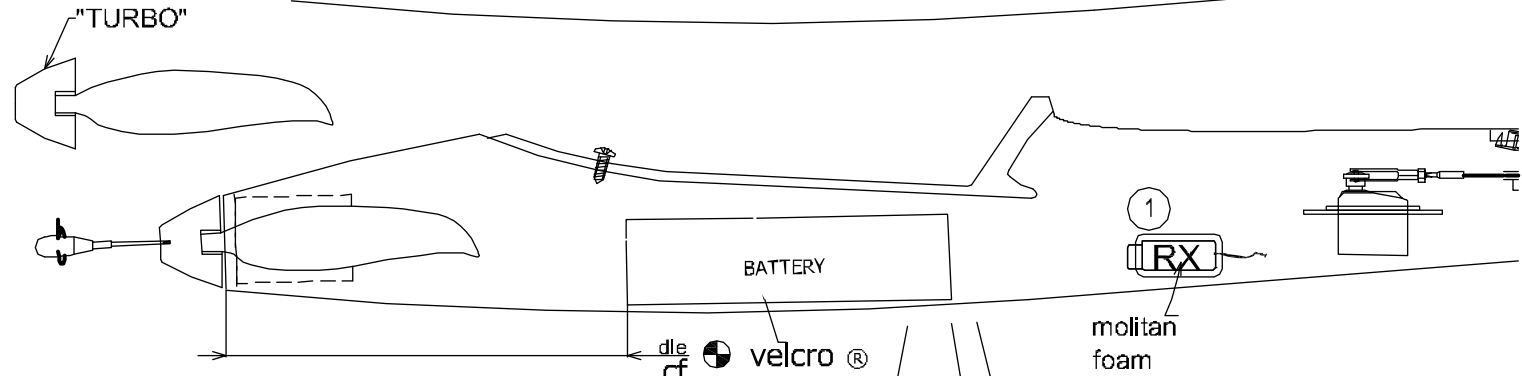
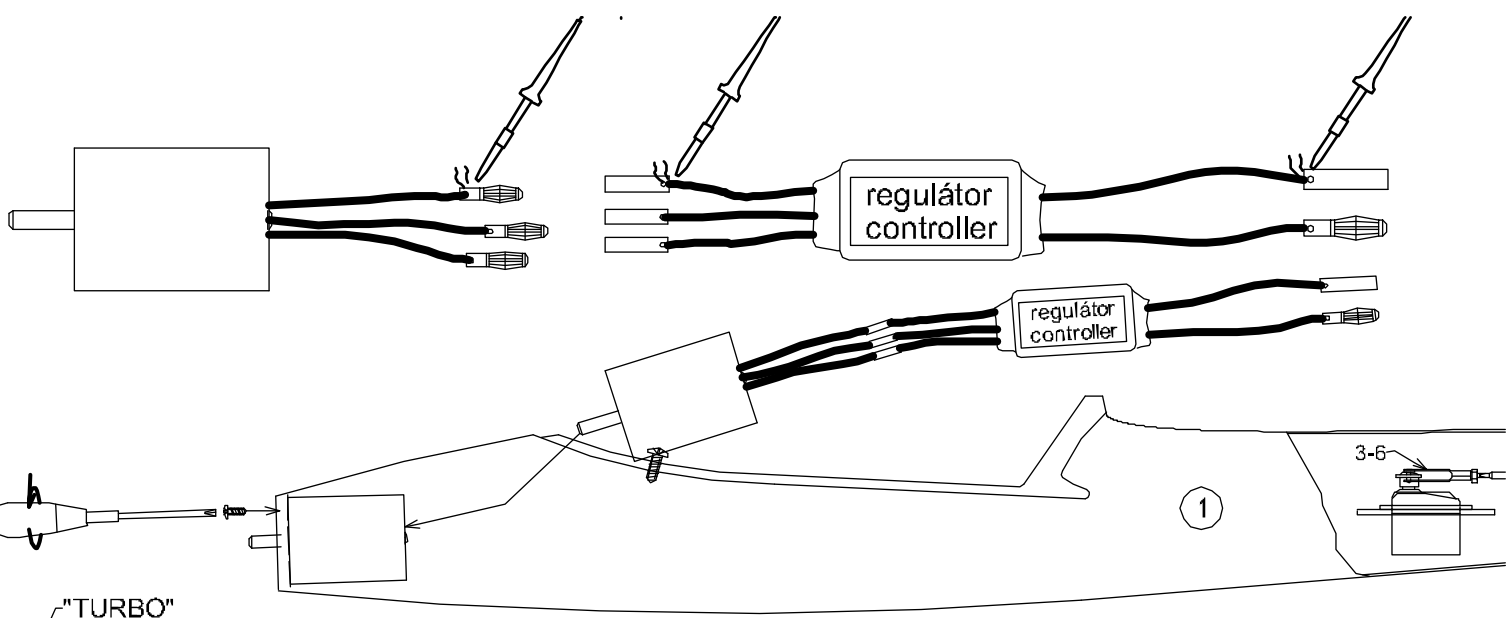

2

2

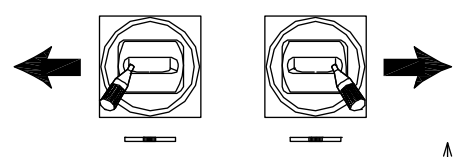
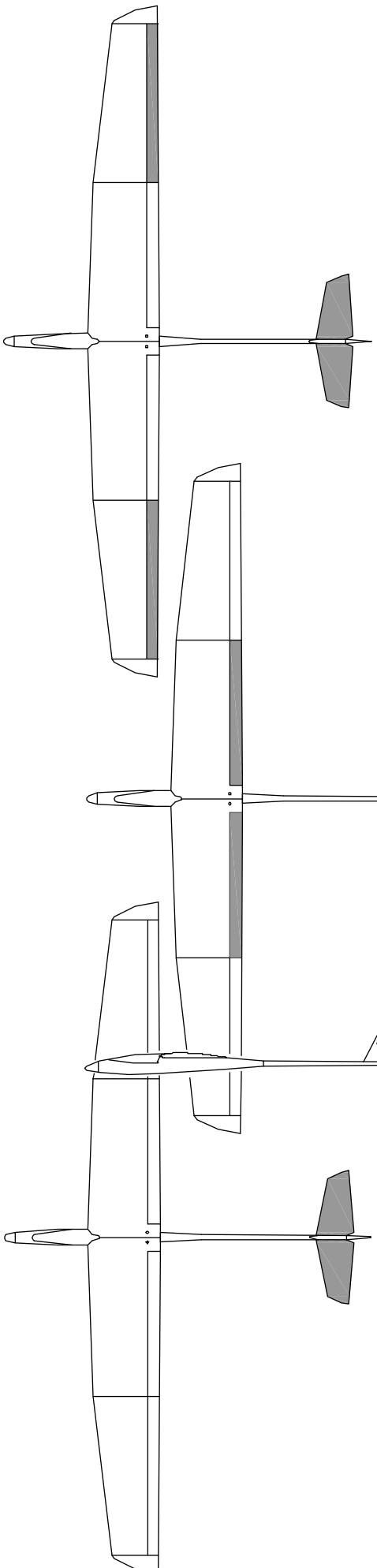

↑ Přistání - 19-22 mm  
Landing

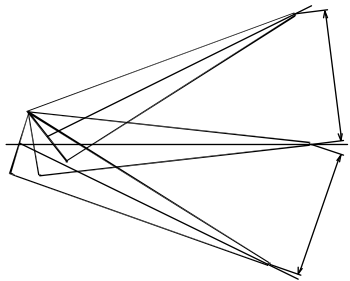

20-23 mm

EXPO 25%

10-13 mm

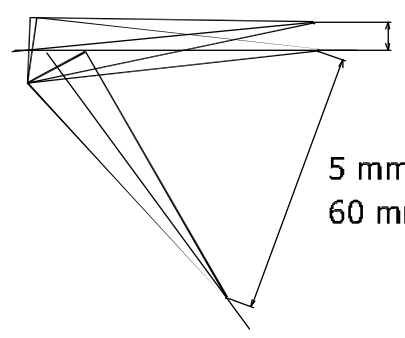
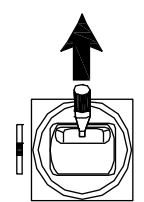

2-3 mm

5 mm - thermik  
60 mm - přistání  
Landing

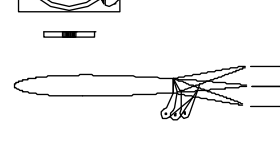
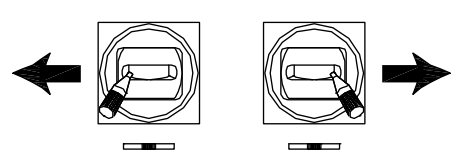
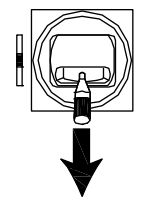

40-50 mm

EXPO 30%

40-50 mm

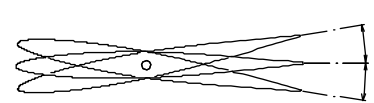
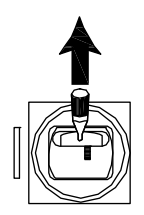

8-10 mm

EXPO 20%

