

ELECTRO SAILPLANE

# ACTIVE



Manufactured by:

**TOPMODEL CZ**

679 05 HABRŮVKA 100 - CZECH REPUBLIC

www.topmodelcz.cz

e-mail: info@topmodelcz.cz

Order N°: 020102

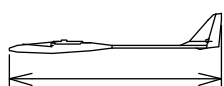

1310mm

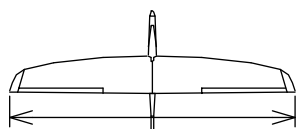

1995mm

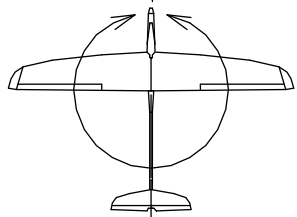

37,2dm<sup>2</sup>  
29,6-35g/dm<sup>2</sup>



1 - 1,3kg

Radio system you'll need :

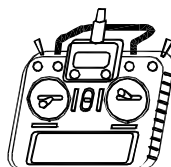

5channel  
with  
6 servos

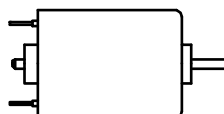

MVS 2,5/1120  
XPower XC 3514/12  
Axi 2814/12

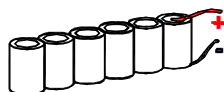

2S-3S Lixx 2-3Ah



MH 32 mod.

*Není-li uvedeno jinak, všechny  
neoznačené míry jsou v milimetrech*  
UNLES STATED, ALL DIMENSIONS  
ARE IN MILIMETERS

## GB - USA Parts list

Part #	Part name	Material, dimensions	Loose	In bag
	building instruction		01	-
1	fuselage	fibreglass	01	-
1-1	engine mount	fibreglass 3 mm	-	01
1-2	servo tray V-tail	plywood 4 x 53 x 47 mm	-	01
1-3	link support	balsa 5 x 10 x 50 mm	-	01
2	wing	balsa assembly	02	-
2-1	aileron	balsa	02	-
2-11	flap	balsa	02	-
24	wing joiner	carbon tube Ø 10/8 x 180 mm	-	01
2-2	wing fixing screw	nylon screw M 4 x 30 mm	-	02
2-21	centering pin	fibreglass Ø 3 x 30 mm	-	01
2-3	captive nut	aluminium M4	-	02
2-31	nut mount	plywood 3 x 23 x 53 mm	-	01
2-4	servo mount	polyurethan	-	04 + 04
2-41	wing servo cover	ABS plastic	-	04
2-5	aileron-flap pushrod	piano wire M2	-	04
2-6	clevis	MPJ 2110	-	04
2-8	aileron horn	fibreglass plate 1 mm	-	02
2-81	flap horn	fibreglass plate 1 mm	-	02
3	V-tail	balsa assembly	01	-
3-2	V-tail screw	steel M3 x 25 mm	-	01
3-21	screw bushing	brass Ø4/3mm L = 12,5 mm	-	01
3-3	screw nut	aluminium M3	-	01
3-31	nut mount	plywood 3 x 12 x 22 mm	-	01
3-5	V-tail link	bowden Ø2 mm L=820mm, piano wire Ø0,8 mm L= 920mm	02+02	-
3-6	threaded link	MPJ 2758	-	02
3-8	horn	fibreglass plate 1 mm	-	02
6	canopy	fibreglass	01	-
6-2	canopy fixing	fibreglass Ø2 x 180 mm	-	01
6-21	mount	plywood 1 x 6 x 12 mm	-	02
7	stickers		01	

### RECOMMENDED EQUIPMENT:

		Pieces		Item No. <a href="http://www.topmodelcz.cz">www.topmodelcz.cz</a>
Transmitter	5 channel			
Receiver	7 channel			
Servo	<a href="#">HS-65HB</a>	2	ailerons	<a href="#">1HI3021</a>
	<a href="#">HS-65MG</a>	2	flaps	<a href="#">1HI3022</a>
	<a href="#">PS1616</a>	2	V-tail	<a href="#">0201616</a>
Motor	<a href="#">MVVS 2,5/1120</a>	1		<a href="#">#2015</a>
Controller	<a href="#">SPIN 33</a>	1		<a href="#">SPIN 33</a>
Spinner	<a href="#">Turbo 40/4/8</a>	1		<a href="#">0201558</a>
Propeller	<a href="#">CAM CARBON 10/7"</a>	1		<a href="#">723431</a>
Battery	<a href="#">Hyperion G3 CX - 3S 2100mAh</a>	1		<a href="#">HP-LG325-2100-3S</a>

### ATTENTION:

This model construction kit is not a toy and is not suitable for children under the age of 14.

Incorrect use of this material could cause material damage or person injury. You are fully responsible for your actions when you use this model.

Fly at a safe distance from occupied zones. Be sure that no one else is using the same frequency as you.

Before first take-off check up please if model aeroplane parts aren't crooked. The reparation is possible through the use of hot-air dryer.

# CZ Seznam dílů

Položka	Název dílu	Materiál, rozměr	Volně / ks	Balíček / ks
	montážní návod		01	-
1	trup	laminát	01	-
1-1	motorová přepážka	sklotextit 3 mm	-	01
1-2	držák serva ocasních ploch	překližka 4 x 53 x 47 mm	-	01
1-3	držák bowdenů	B 5 x 10 x 50 mm	-	01
2	křídlo	balsa konstrukční	02	-
2-1	křídélko	balsa	02	-
2-11	vztlaková klapka	balsa	02	-
24	spojka křídla	uhlík Ø 10/8 x 180 mm	-	01
2-2	uchycení křídla	šroub M 4 x 30 mm	-	02
2-21	aretační kolík	laminát Ø 3 x 30 mm	-	01
2-3	uchycení křídla	matice AL. M4	-	02
2-31	podložka matice	překližka 3 x 23 x 53	-	01
2-4	držák serva	polyuretan 13mm; 11mm	-	04 + 04
2-41	krytka serva	ABS folie	-	04
2-5	táhlo křídélka a klapky	ocel	-	04
2-6	koncovka táhla	MPJ 2110	-	04
2-8	páka křídélka	sklotextit 1 mm	-	02
2-81	páka klapky	sklotextit 1 mm	-	02
3	ocasní plochy	balsa konstrukční	01	-
3-2	šroub OP	M3 x 25	-	01
3-21	průchodka šroubu	MS Ø4/3mm L = 12,5	-	01
3-3	matice OP	AL M3	-	01
3-31	podložka matice	př. 3 x 12 x 22	-	01
3-5	táhlo OP	bowden Ø2 mm L=820mm, ocel drát Ø0,8 mm L= 920mm	02 + 02	-
3-6	koncovka táhla	MPJ 2758	-	02
3-8	páka	sklotextit 1 mm	-	02
6	kabina	laminát	01	-
6-2	uchycení kabiny	laminát Ø2 x 180 mm	-	01
6-21	podložka	př. 1 x 6 x 12	-	02
7	obtisky		01	

## DOPORUČENÉ PŘÍSLUŠENSTVÍ :

		kusů		objednací číslo <a href="http://www.topmodelcz.cz">www.topmodelcz.cz</a>
vysílač	5 kanál			
přijímač	7 kanál			
servo	<a href="#">HS-65MG</a>	2	křídélka	<a href="#">1HI3022</a>
	<a href="#">Servo PS1616</a>	2	ocasní plochy	<a href="#">0201616</a>
	<a href="#">HS-65HB NEW 1xBB</a>	2	vztlakové klapky	<a href="#">1HI3021</a>
motor	<a href="#">MVVS 2,5/1120</a>	1		<a href="#">#2015</a>
regulátor	<a href="#">SPIN 33</a>			<a href="#">1RC23202</a>
kužel	<a href="#">TURBO 40/4,0/8</a>	1		<a href="#">0201558</a>
vrtule	<a href="#">CAM CARBON 10/7"</a>	1		<a href="#">723431</a>
aku	<a href="#">Hyperion G3 CX - 3S 2100mAh</a>			<a href="#">HP-LG325-2100-3S</a>

Před prvním startem zkontrolujte jestli nejsou díly modelu zkroucené.  
Náprava je možná pomocí horkovzdušné pistole .

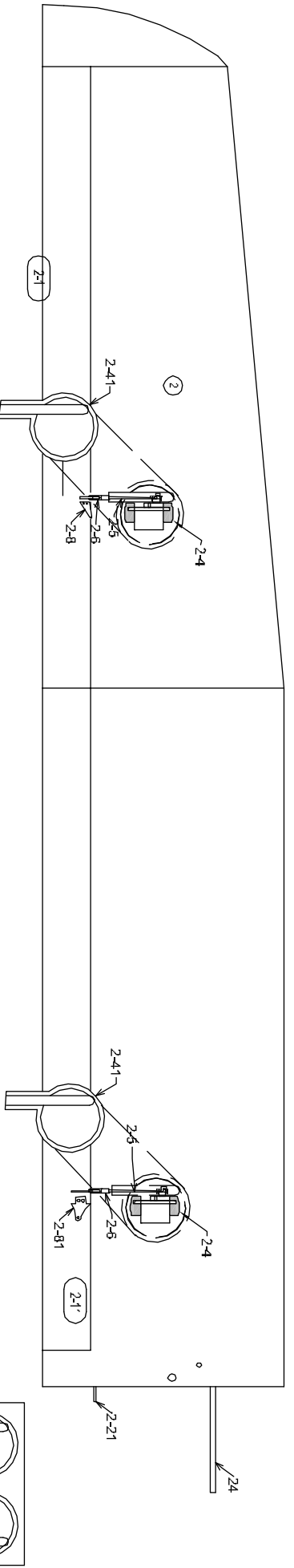
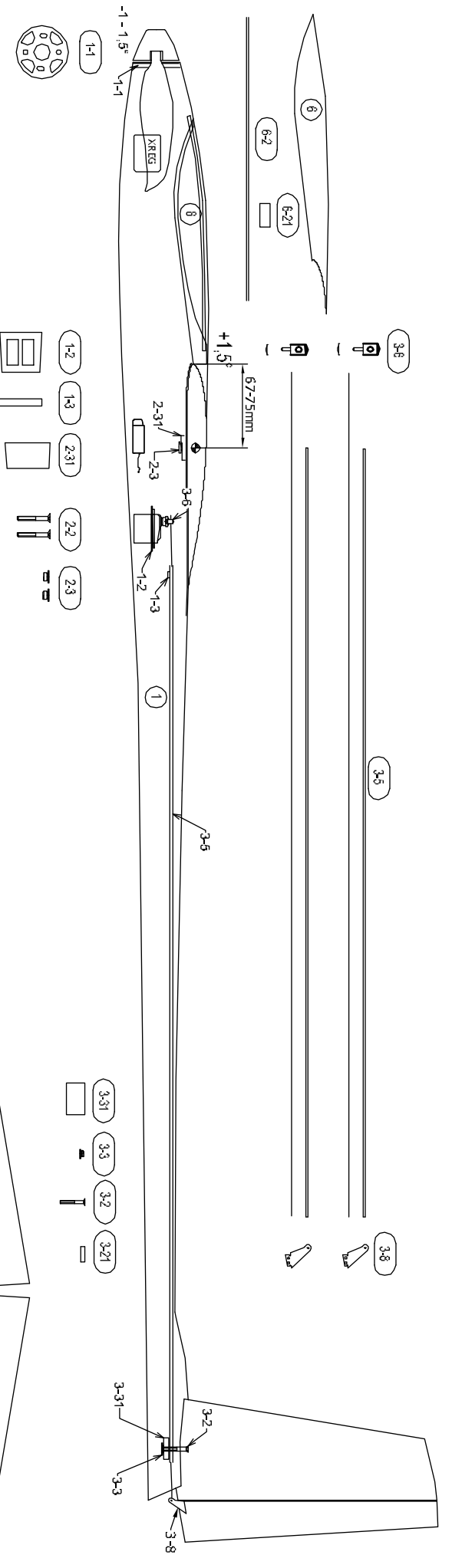

# ACTIVE

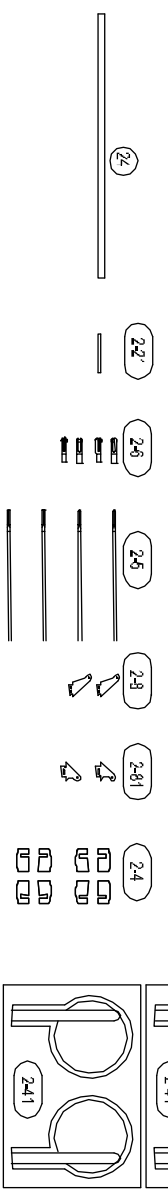

© V. 2011 TOPMODEL CZ Manufactured by TOPMODEL CZ s.r.o. 679 05 HABRŮVKA 100 - Better made in the Czech Republic  
 www.topmodelcz.cz e-mail: info@topmodelcz.cz

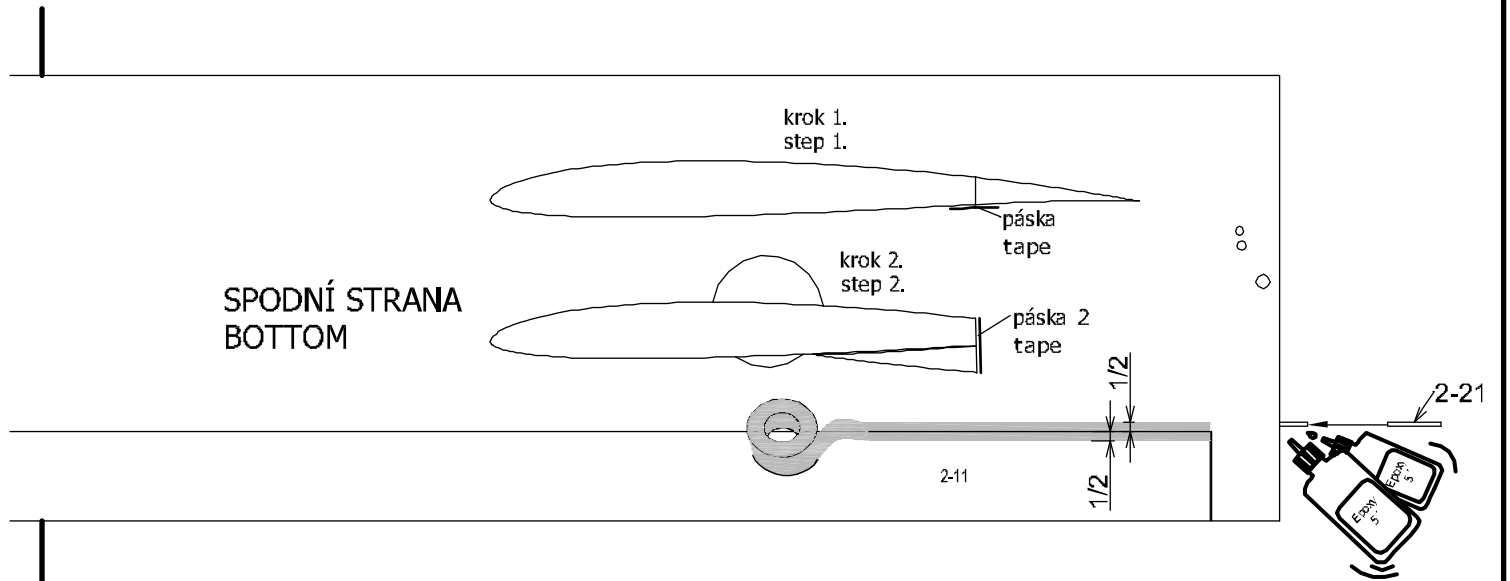
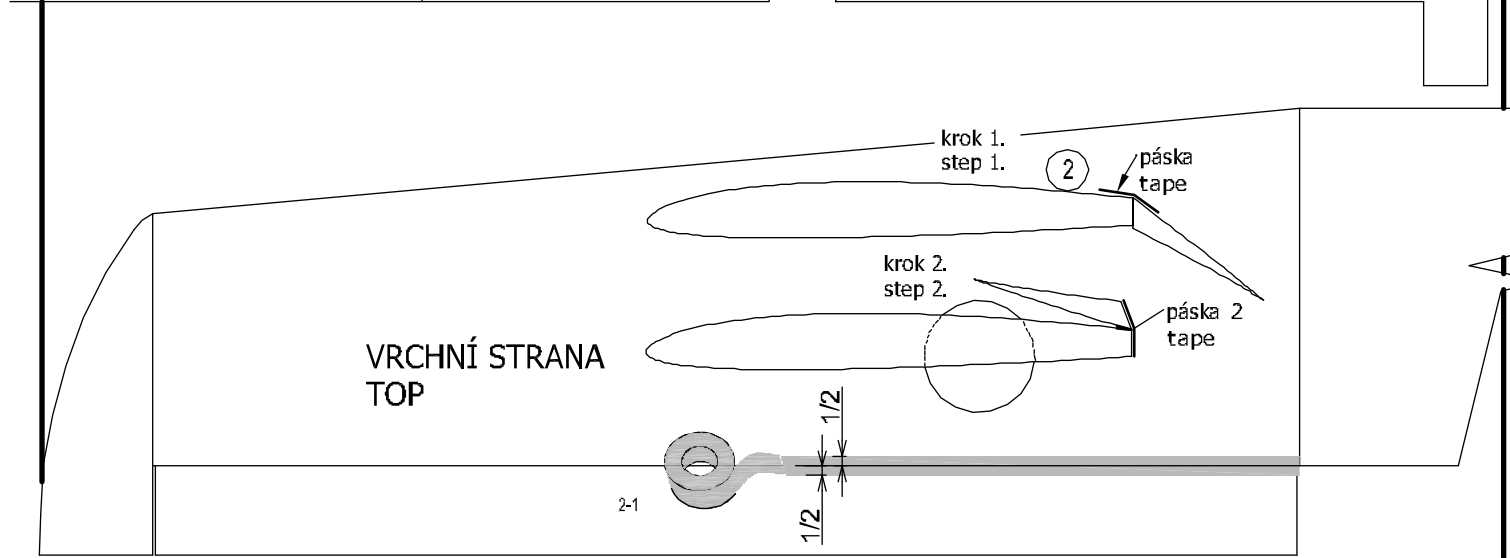
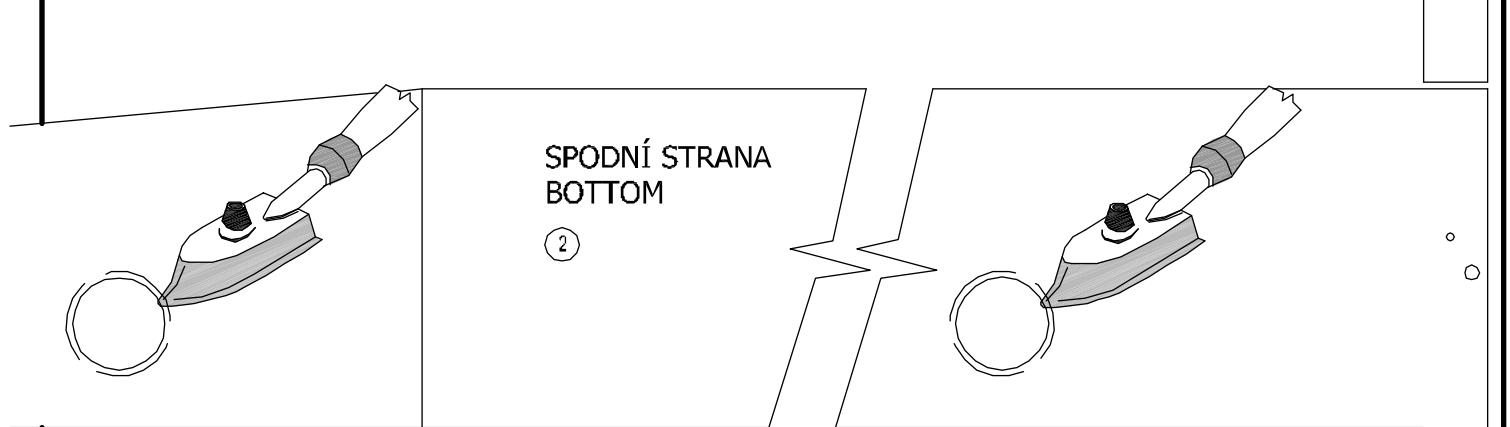
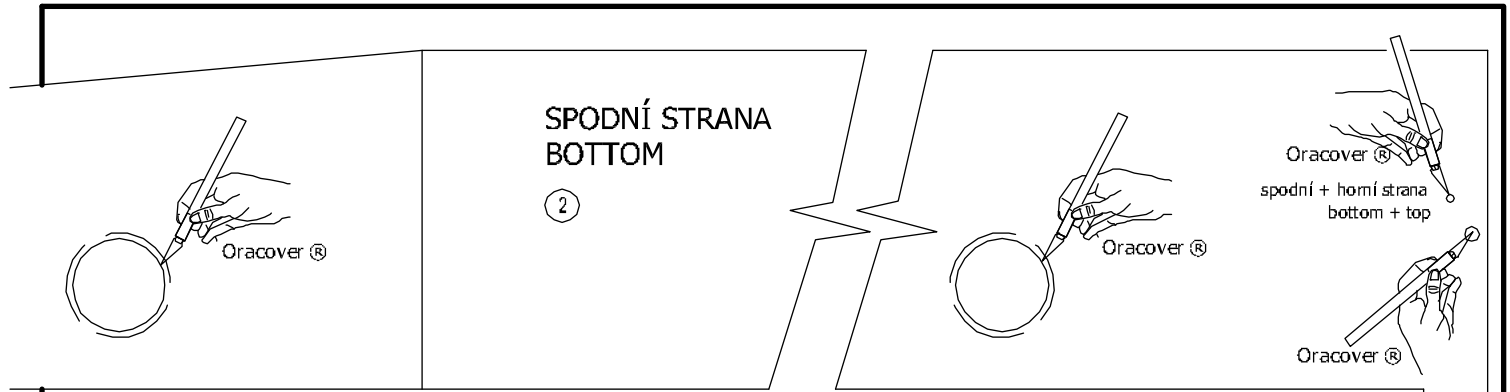

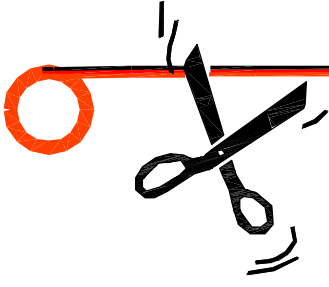

~200mm - 2x pro servo klapek  
for flaps servo

~850mm - 2x pro servo křidélek  
for aileron servo

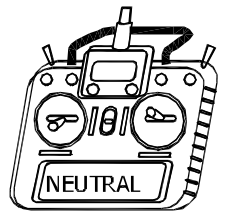
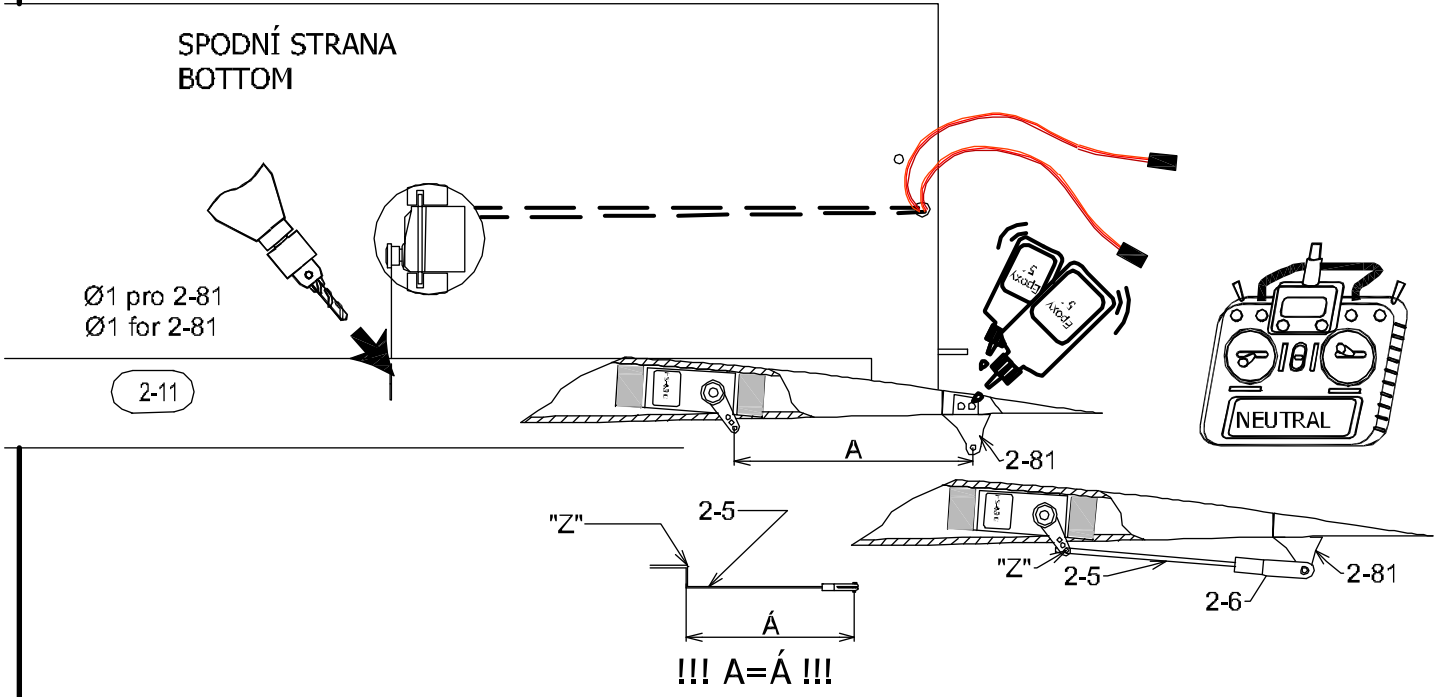
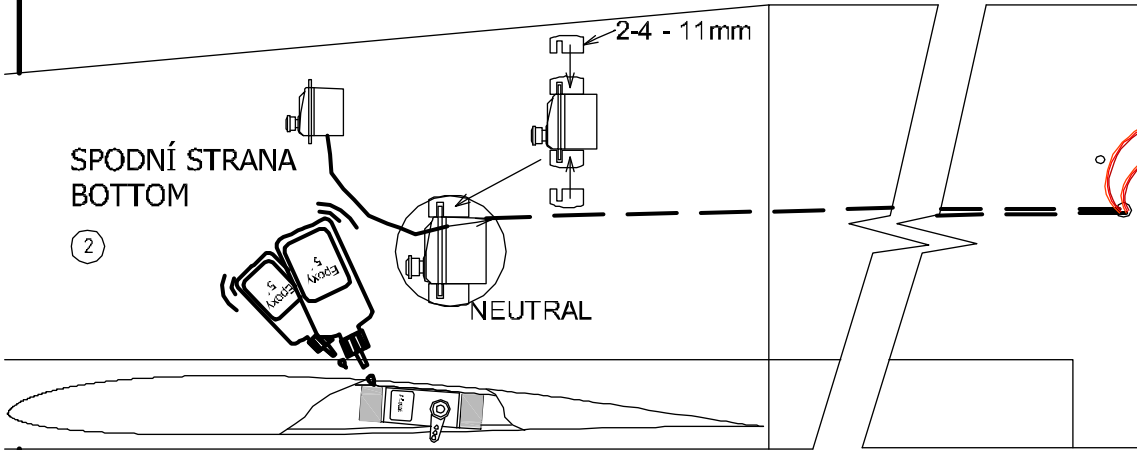
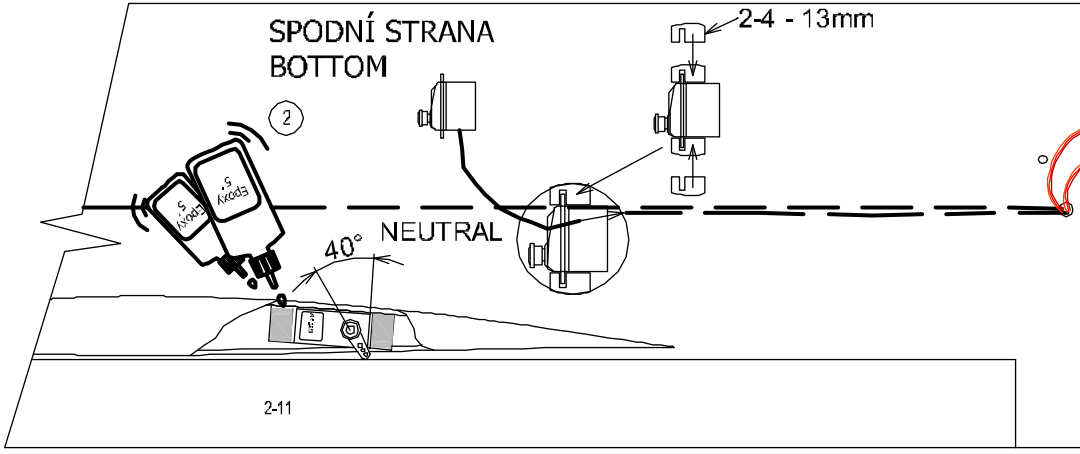
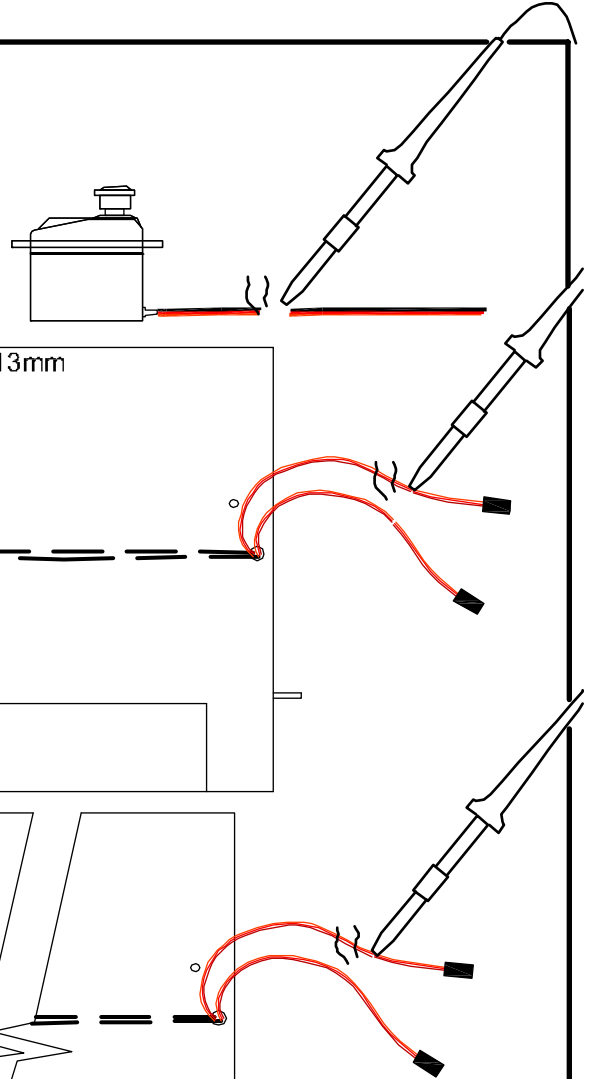

SPODNÍ STRANA  
BOTTOM

Ø1 pro 2-8  
Ø1 for 2-8

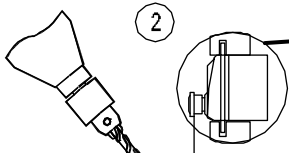

2-1

"Z"

2-5

!!! A=Á !!!

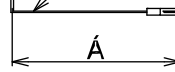

2-8

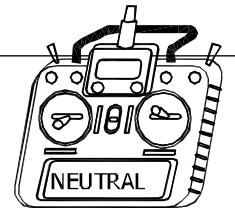

A

"Z"

2-5

2-6

2-8

SPODNÍ STRANA  
BOTTOM

2

kontaktní lepidlo (Chemopren)  
dry-bond adhesive

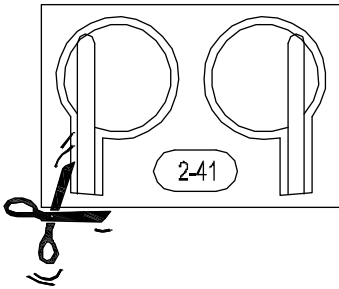

2-41

2-41

kontaktní lepidlo (Chemopren)  
dry-bond adhesive

SPODNÍ STRANA  
BOTTOM

2

2-41

